

TENDER DOCUMENT

Tender for Supply, Installation and Commissioning of Passive LAN Infrastructure for TEC, New Delhi

No. 2-14/2019-MM/TEC
Dated 14.10.2019



ISO 9001:2015

**Government of India
Ministry of Communications
Department of Telecommunications
Telecommunication Engineering Centre
Khurshid Lal Bhawan, Janpath, New Delhi - 110001**

(Visit us at www.eprocure.gov.in or www.tec.gov.

TABLE OF CONTENT

SECTION - I NOTICE INVITING TENDER.....3

SECTION - II INSTRUCTIONS TO BIDDERS.....4

SECTION - III GENERAL (COMMERCIAL) CONDITIONS OF CONTRACT.....12

SECTION - IV SPECIAL CONDITIONS OF CONTRACT19

SECTION - V SCHEDULE OF REQUIREMENT.....23

ANNEXURE - I PROFILE OF BIDDER.....26

ANNEXURE - II NO NEAR-RELATIVE DECLARATION/CERTIFICATE27

ANNEXURE - III PERFORMANCE SECURITY BOND FORM28

ANNEXURE - IV BID FORM30

ANNEXURE -V DIAGRAMS 31-32

SECTION - I NOTICE INVITING TENDER

**Government of India
Ministry of Communications
Department of Telecommunications
Telecommunication Engineering Centre
Gate No. 5, Khurshid Lal Bhawan, Janpath,
New Delhi – 110001**

Tender No. 2-14/2019-MM/TEC
Dated 14.10.2019

Tenders are invited by Sr. DDG, Telecom Engineering Centre (TEC), on behalf of President of India, only from Reputed, Experienced and financially sound IT/Networking/System Integrator companies for Supply, Installation and Commissioning of Passive LAN Infrastructure at TEC, K.L. Bhawan, Janpath, and New Delhi.

Approximate cost of Tender	Rs. 13.35 Lacs
Cost of Tender Document	
Earnest Money Deposit	Rs. 30,000
Date/Time of Publishing of e-Tender	15:00 Hrs of 14.10.2019
Document Download Start Date/Time	15:00 Hrs of 14.10.2019
Document Download End Date/Time	15:00 Hrs of 04.11.2019
Clarification Start Date/Time	15:00 Hrs of 14.10.2019
Clarification End Date/Time	17:00 Hrs of 24.10.2019
Bid Submission Start Date/Time	09:00 Hrs of 26.10.2019
Bid Submission End Date/Time	15:00 Hrs of 04.11.2019
Date/Time of opening of Techno-commercial Bid	15:00 Hrs of 05.11.2019

The tender document is available on website <http://eprocure.gov.in>. The intending bidders may download the e-tender document from the above mentioned website. The interested bidders may submit the bids online at <https://eprocure.gov.in> in two bids systems {i.e. (i) Techno-commercial Bid and (ii) Financial Bid} in the prescribed proforma. Bids are to be submitted only online through the e-procurement portal <https://eprocure.gov.in/eprocure/app>. All the documents in support of bid are also to be scanned and uploaded along with the tender document. Bid sent by any other mode will not be accepted.

The bidder shall upload the e-bids and submit original Demand Drafts/Banker's Cheque i/r/o EMD drawn in any Scheduled Bank in India, in favour of Accounts Officer (Cash) TEC, New Delhi, payable at New Delhi, in Room No 257, Khurshid Lal Bhawan, TEC, before scheduled date & time. E-Bid submitted without EMD in the prescribed formats will not be accepted.

**ADG (MM)
TEC, New Delhi
FAX No.: 011-23725144**

SECTION - II

INSTRUCTIONS TO BIDDERS

1.0 DEFINITIONS:

- a. "The Purchaser" means the Telecommunication Engineering Centre (TEC).
- b. "The e-bidder" means a company or firm who participates in this tender and submits its e-bid. (Hereafter e-bidder shall be referred as bidder).
- c. "The Supplier/Contractor" means a company or firm supplying the goods under the contract.
- d. "The Goods" means all item such as structure CAT-6 cable, Patch Panel, Patch Cords, Information Outlet (IO) Boxes, LIU, Rack Mount Fiber Termination Unit, Optical Fiber Cable, Rack with Cable Manager, PVC Channel, PVC Ducts, Pigtail, Connectors and/ or other materials, which the supplier is required to supply to the purchaser under the contract.
- e. "The Advance Purchase Order" means the intention of purchaser to place the purchase order on the successful bidder.
- f. "The Purchase Order" means the order placed by the purchaser on the supplier signed by the purchaser including all attachments and appendices thereto and all documents incorporated by reference therein. The purchase order shall be deemed as "Contract" appearing in the document.
- g. "The Contract Price" means the price payable to the supplier under the purchase order for the full and proper performance of its contractual obligations.
- h. The services mean all the jobs that the contractor is required to perform under the contract.
- i. The validation is a process of testing the equipment as per the tender specifications to ascertain proper functioning of the network.

1.1 REGISTRATION AT E-PROCUREMENT PORTAL:

For participating in bidding through the e-procurement portal, it is necessary for the bidders to be registered users of the e-procurement portal; <http://eprocure.gov.in>. For Bidders guidance **Bidders Manual Kit** is available at <http://eprocure.gov.in/eprocure/app>.

2.0 ELIGIBLE BIDDERS:

- 2.1 The company should be registered and incorporated in India under the companies' act 1956 or Companies Act,2013. In case of firms, it shall be registered under the relevant law. Supporting document as prescribed in clause 15.4 (a) of section II of the tender document shall be submitted in this regard.
- 2.2 Bidder should have the experience of Supply, Installation and Commissioning of Passive LAN Infrastructure in large and reputed organizations like Govt. offices/PSUs/Private companies or firm during any of the last four financial years. For this, bidder shall submit copies of purchase orders/contracts combined worth not less than Rs. 10 Lakhs during any or all these financial years. Supporting document as prescribed in clause 15.4 (b) of section II of the tender document shall be submitted in this regard.

3.0 COST OF BIDDING:

- 3.1 The bidder shall bear all costs associated with the preparation and submission of the bid. The Purchaser, will in no case, be responsible or liable for any costs, regardless of the conduct or outcome of the bidding process.

- 3.2 Prospective bidders may visit the TEC Building, Gate No.5, Khurshid Lal Bhawan, Janpath, New Delhi, to get fully acquainted with the schedule of work / scope of work before filling in and submitting his bid. No claim, whatsoever, will be entertained for any alleged ignorance thereof.

4.0 DOCUMENTS COMPRISING THE e-TENDER:

- 4.1 The goods required, bidding procedures and contract terms are prescribed in the Bid Document. The Bid Document includes:
- a. Notice inviting tender
 - b. Instructions to bidders
 - c. General (commercial) conditions of contract
 - d. Special conditions of contract
 - e. Schedule of requirement
 - f. Profile of bidder
 - g. No near Relative Declaration/Certificate
 - h. Performance security bond form
 - i. Bid Form
 - j. Diagram
- 4.2 Price schedule shall be filled separately in Financial Bid of the tender, as per the procedure given in bidder's manual kit.
- 4.3 The bidder is expected to examine all instructions, forms, specifications, terms and conditions in the tender document and amendments/ clarifications, if any, before submitting it. Failure to furnish all information as per the e- tender document or submission of e-bid not as per the requirement of e-tender document in every respect will be at the bidder's risk and result in rejection of the said e-bid.

5.0 CLARIFICATIONS/AMENDMENTS OF e-TENDER DOCUMENT:

- 5.1 A prospective bidder requiring any clarification on the tender document shall notify/upload its queries on procurement portal prior to **17:00 HRS OF 24.10.2019**
- 5.2 Purchaser shall upload the response to such queries, which are received in due time, generally by 7 days prior to the date of opening of the bids.
- 5.3 At any time, prior to the date of submission of bids, Purchaser may, for any reasons whether at its own initiative or in response to a clarification sought by a prospective bidder, modify the e-tender document by amendments.
- 5.4 The amendments/clarifications, if any, which are uploaded on the portal www.eprocure.gov.in, shall form an integral part of the tender document, and shall be binding on all bidders.
- 5.5 It shall be the sole responsibility of the prospective bidder to check the web site <http://eprocure.gov.in> from time to time for any amendment in the e-tender documents. In case of failure to get the amendments, if any, the department shall not be responsible for it. Interested bidders are required to keep abreast of latest corrigendum (s) issued by Purchaser till the date of submission of bid.

6.0 DOCUMENTS COMPRISING THE BID AND MARKING THEREOF:

The bid prepared by the bidder shall comprise of:

- (1) **Techno-commercial bid, and**
- (2) **Financial bid**

- 6.1 All documents to be submitted under the bid must be uploaded in pdf format along with scanned copy of Demand Draft/Banker's cheque/BG for earnest money deposit. However, original Demand Drafts/Banker's Cheque i/r/o EMD shall be submitted in Room No 257, Khurshid Lal Bhawan, TEC upto 15:00 Hrs of 04.11.2019. The purchaser reserves the right to seek actual documents for any uploaded documents during evaluation of the e-bid.
- 6.2 The **"Techno-commercial e-Bid"** for tender no. **2-14/2019-MM/TEC dated 14.10.2019** should contain
- a. Scanned copy of Demand Draft/Banker's Cheque/BG from any Scheduled Bank of India for the prescribed amount Rs. 30,000/- (Rs. Thirty Thousand only) of Earnest Money Deposit, if applicable.
 - b. Latest NSIC/MSME certificates and documents, if applicable
 - c. Authorization letter for signing the bid document(s) in the form of duly attested Board Resolution/Power of Attorney or letter of authorization duly signed by all partners/proprietor on the letter head of the firm/company, as applicable.
 - d. Attested copy of Certification of registration of company/firm as per company's act. The PF & ESIC registration certificate if applicable.
 - e. Copy of ITR FY 2016-17, 2017-18 and 2018-19.
 - f. Copies of Purchase Order(s)/Contract(s) combined worth not less than 10 lakhs executed during any or all of the last 4 financial years () as per Clause No. 2.2 of Section II.
 - g. Certificate confirming satisfactory performance against the purchase orders (of clause No. 6.2 (f)).
 - h. List of partners/directors of the bidder along with Partnership deed or Article/Memorandum of Association, as applicable.
 - i. Copy of PAN card/ GIR card and copy of Sales Tax Registration Certificate of the organisation.
 - j. Copy of GST registration and latest GST return submitted.
 - k. Duly filled and signed Profile of bidder and bid form as per Annexure I & IV.
 - l. No near relative certificate/declaration as per Annexure-II.
 - m. Submit tender document consisting of all sections and Annexures, subsequent amendments/clarifications if any, duly filled and digitally signed by the authorised signatory of the bidder.
- 6.3 **Price schedule for tender no. 2-14/2019-MM/TEC dated 14.10.2019** shall be filled separately as given in financial bid.
- 6.4 The bidder is expected to examine all instructions, forms, terms & conditions and specifications in the Tender Document and amendments/ clarifications, if any, and submit the bid accordingly.
- 6.5 The bidder shall furnish a clause-by-clause compliance of all the terms & conditions of the tender demonstrating substantial responsiveness **in the form of signing & stamping all the pages of the original bid document and supporting documents by the authorized person/persons.** In case of deviations, a statement of deviations and exceptions shall be given by the bidder.
- 6.6 No tender shall be uploaded after 15:00 Hrs of 04.11.2019. Only in case the last date of submission of bids is declared as Central Government holiday in Delhi, the original EMD will be accepted up to the next working day till the same time and the Techno-commercial Bid will be opened on the next working day at the scheduled time.

- 6.7 Tender document, as downloaded, must be submitted without making any additions, alternations. Tender document modified in any manner is liable to be rejected.
- 6.8 The purchaser reserves the right to accept/reject any/all/part of the bids without assigning any reason.
- 6.9 Any bid unaccompanied by EMD in variance with the instructions herein, is liable to be rejected summarily.

7.0 BID PRICES:

- 7.1 The prices should be quoted only in Indian Rupees as per Price Schedule only. The Unit price after discount, if any and all other components need to be quoted individually.
- 7.2 It is mandatory to quote the rate for all the items mentioned in Price Schedule.
- 7.3 The bidder must quote a definite price for each item/component. In case the prices of any item/component are included in some other item/component, it should be mentioned specifically in the remark column, failing which the bid shall be rejected. However, the Price of that item/component shall be indicated as '0' (Zero) in the relevant column.
- 7.4 The column for quoting "Unit Rate (After discount, if any) In Figures to be entered by the Bidder" should not be left blank. If there is no specific price towards any item/component, the same shall be indicated as '0' (Zero) in the relevant column.
- 7.5 In case any column other than "Unit Rate (After discount, if any) i.e taxes or any levies in Figures to be entered by the Bidder" of Price Schedule is left blank then the value shall be treated as inclusive of the base rate.
- 7.6 The benefit arising out of reduction in rates of taxes/levies before the supplies made, shall be passed on to purchaser.
- 7.7 Rates of requisite items only should be quoted against each item. In case multiple prices are quoted, the highest prices shall be considered during evaluation of financial bids.
- 7.8 A bid submitted with an adjustable or variable price will not be accepted.
- 7.9 The price approved by the purchaser for procurement will be inclusive of all levies and taxes i.e., GST, for delivery upto the Consignee. Increase in GST rates decided from time to time by Government shall be paid to the contractor on production of document whereas decrease in GST rates decided, from time to time by Government shall be adjusted in favour of purchaser.
- 7.10 Prices quoted in the price schedule shall remain fixed, firm and final and will remain valid during the currency of the contract.

8.0 EARNEST MONEY DEPOSIT (BID SECURITY):

8.1 FURNISHING OF EMD

- a. Earnest Money Deposit (refundable) of Rs. 30,000 (**Rs. Thirty Thousand only**) is to be furnished with the bid by way of Demand Draft/Banker's Cheque/Bank Guarantee / receipt valid up to 225 days, from the date of opening of bids, from any scheduled bank in India, PLEDGED in favour of ACCOUNTS OFFICER (Cash), TEC, payable at New Delhi.
- b. The bidder desirous of claiming EMD exemption, should submit their latest and valid NSIC/MSME certificate(s) and documents in respect of their monetary limit and financial capability duly certified by NSIC.
- c. Any previous payment/deposit due on TEC/DoT will not be adjusted against the EMD or Performance Security under this contract. **Failure to furnish Earnest Money Deposit shall result in summary rejection of the bid.**

8.2 FORFEITURE OF EMD

The EMD shall stand forfeited if

- a. The bidder withdraws his offer before initial bid validity.
- b. The successful bidder, whose tender is accepted, fails or refuses to furnish the security deposit amount within the stipulated time, or fails or refuses to execute the contract.
- c. It is established that near-relatives of bidder is working in the units of DoT, as detailed in this document.
- d. In case it is found that tender document submitted by the bidder has been altered by way of tampering or doctoring.

In the above cases, the bidder will also not be eligible to participate in the tender for same item for one year from the date of any of the above events.

8.3 REFUND/RELEASE OF EMD

- a. No interest would be payable for any period on EMD Performance Security Deposit or on any other amount lying with the purchaser.
- b. The EMD amount/BG will be refunded/released only after finalisation of tender, and on receipt of written request from the unsuccessful bidders.
- c. The EMD of the successful bidder will not be adjusted against performance security deposit. It will be refunded/released only after the receipt of the prescribed Performance Security Deposit/Bank Guarantee.

9.0 PERIOD OF VALIDITY OF BIDS:

- a. The prices quoted in the bid shall remain valid for acceptance by the purchaser for a period of 180 days from the date of opening of bids.
- b. In case the Purchaser requests, in writing, the bidders to extend the period of validity of their bids, they may confirm the extension of the validity of their bids in writing, unconditionally. In such a case, the validity of the EMD, if furnished, may also be extended suitably. A bidder may refuse the request without forfeiting its Earnest Money Deposit. A bidder accepting the request and granting extension will not be permitted to modify its bid.

10.0 SUBMISSION OF BIDS:

- 10.1 The bidders shall upload their bids online at e-procurement portal, in response to the e-tender published by the department. Bid submission can be done from 09:00 Hrs of 26.10.2019 till 15:00 Hrs of 04.11.2019 of receipt of e-bids, as mentioned in the schedule in NIT (Section-I). **Payments for EMD must be received by the Purchaser at the address Assistant Director General (MM), Room No. 257, TEC, Gate No.5, Khurshid Lal Bhawan, Janpath, New Delhi not later than the prescribed time on due date [15:00 Hrs of 04.11.2019].** In case, the last date of submission of bids is declared as central government holiday in Delhi, the original EMD will be accepted up to the next working day till the same time and the Techno-commercial Bid will also be opened on the next working day at the scheduled time.
- 10.2 The bidder should submit their e-bid considering the server time displayed in the e-procurement website. This server time is the time by which the e-bid submission activity will be allowed till the permissible time on the last/end date of submission indicated in the e-tender schedule.
- 10.3 Once the e-bid submission date and time is over, the bidders cannot submit their e-bid.
- 10.4 The Purchaser shall not be responsible for any kind of delay in submission of e-bid due to any reasons. No other mode of submitting the bid except the online method will be entertained.
- 10.5 The Purchaser shall not be responsible if the bids are uploaded in any other portal than the one specified.

- 10.6 The Purchaser may, at its discretion extend this deadline for the submission of the bids by amending the tender document in accordance with clause 5 of Section II in which case all rights and obligations of the Purchaser and bidders (previously subject to the earlier deadline) will be subject to the deadline as extended.
- 10.7 Not more than one bid shall be permitted from a single bidder otherwise all the bids submitted by such bidder shall be summarily rejected.

11.0 LATE BID:

The server time indicated in the bid management window on the e-procurement website <http://eprocure.gov.in> will be the time by which the e-bid submission activity will be allowed till the permissible date and time scheduled in the e-tender. Once the e-bid submission date and time is over, the bidder cannot upload the e-bid.

12.0 MODIFICATION AND WITHDRAWAL OF BIDS:

The bidder may modify, withdraw or re-submit its e-bid online only, before the bid submission date and time as per provisions available in CPP Portal.

13.0 OPENING OF BIDS:

- 13.1 A two stage process shall be adopted in the evaluation of the bids. The purchaser shall open Techno-commercial bids online and check the Techno-commercial bids of proposal online.
- 13.2 Authorized representatives may check portal for status of tender opening, online.
- 13.3 The date fixed for opening of bids, if subsequently declared as central government holiday in Delhi, the revised date of schedule will be notified. However, in absence of such notification, the bids will be opened in the next working day at the same time.

14.0 CLARIFICATION OF BIDS BY THE PURCHASER:

To assist in the examination, evaluation and comparison of bids, the purchaser may, in exceptional situations, at its discretion, seek clarification/document(s) of its bid from the bidder. Only the information furnished, by the bidder, shall be considered in future evaluation. However, no post-bid clarification at the initiative of any bidder shall be entertained.

15.0 TECHNO-COMMERCIAL BID EVALUATION:

- 15.1 The bids will be evaluated Techno-Commercially to determine whether they are complete, whether documents have been properly submitted, and whether bids are generally in order and qualify for opening and evaluation of financial bid.
- 15.2 Bid shall be considered substantially responsive if it conforms to the terms and conditions of the tender document.
- 15.3 The purchaser or his authorized representatives shall have the right to inspect the works, offices, showrooms, service centres etc. of the techno commercially qualified bidder, for verification of facts furnished by the bidder in support of his bid documents before opening the financial bid and the bidder is bound to answer any query made by the purchaser during the course of such inspection.
- 15.4 The bidders not submitting the documents as per the eligibility conditions (Clause 2.0) shall be considered substantially non-responsive and their bids shall be summarily rejected. The following documents are to be submitted against the eligibility conditions:
- a) Attested copy of Certification of registration of company/firm as per company's act.
 - b) Copies of Purchase Order(s)/Contract(s) combined worth not less than 10

lakhs executed during any or all of the last 4 financial years () as per Clause No. 2.2 of Section II.

- 15.5 Unresponsive Tenders: Some important points on the basis of which a tender may be declared as unresponsive and be ignored during the initial scrutiny are:
- i) The tender is not in the prescribed format or is unsigned or not signed as per the stipulations in the bid document;
 - ii) The required EMD has not been provided or exemption from EMD is claimed without acceptable proof of exemption;
 - iii) The tenderer has quoted for goods manufactured by a different firm without the required authority letter from the proposed manufacturer;
 - iv) The bid departs from the essential requirements specified in the bidding document; or
 - v) Against a schedule in the list of requirements in the tender enquiry, the tenderer has not quoted for the entire requirement as specified in that schedule.

16.0 FINANCIAL BID OPENING/FINANCIAL EVALUATIONS AND COMPARISON OF BIDS:

- 16.1 The purchaser shall shortlist only those bidders who are eligible and have submitted substantially techno-commercially responsive bid for opening of financial bid. Successful bidders would be intimated regarding opening of financial bids. The Financial Bids of techno-commercially unsuccessful bidders would not be opened.
- 16.2 Prices quoted in the Price Schedule only will be considered for evaluation.
- 16.3 The evaluation and comparison of responsive bids shall be done on the basis of quoted price of all tendered items including all taxes, levies, duties etc., as indicated in the Price Schedule.
- 16.4 The purchaser may waive any minor infirmity or non-conformity or irregularity in a bid which does not constitute a material deviation, provided such waiver does not prejudice or affect the relative ranking of any bidder.
- 16.5 In case of difference between the total price indicated in figures and words, the amount indicated in words shall prevail.

17.0 CONTACTING THE PURCHASER:

- 17.1 No bidder shall try to influence the purchaser on any matter relating to its bid.
- 17.2 Any effort by a bidder to influence the purchaser in the purchaser's bid evaluation, bid comparison or contract / award decision or any other matter related to this bid shall result in the rejection of the bid of that bidder.

18.0 PURCHASER'S RIGHT TO ACCEPT ANY BID AND TO REJECT ANY OR ALL BIDS:

The Purchaser reserves the right to accept or reject any bid, and to annul the bidding process and reject all bids, at any time prior to award of contract without assigning any reason whatsoever and without thereby incurring any liability to the affected bidder or bidders on the grounds for the Purchaser's action.

19.0 PLACEMENT OF ORDER:

- 19.1 The Purchaser shall consider placement of Advance Purchase orders on the bidder whose offer has been found techno-commercially and financially acceptable. The tender will be awarded to the lowest (L-1) bidder.
- 19.2 The purchaser shall place an Advance Purchase Order of the tendered quantity on the bidder whose offer has been accepted. The bidder shall, within the stipulated time, furnish performance security in conformity with the terms and

conditions, in the form of a bank guarantee as per the Performa enclosed at Annexure III, from any scheduled bank in India.

- 19.3 Failure to furnish performance security within the stipulated time may result in cancellation of Advance Purchase Order along with forfeiture of the EMD.
- 19.4 Purchase Order will be placed only after acceptance of the performance security submitted by the bidder.
- 19.5 The issue of Purchase Order for passive LAN Infrastructure such as Structure CAT-6 Cable, Patch Panel 25 ports with loaded IO modules, Patch Cords, Information Outlet (IO) Boxes, 2 port LIU, 24 port rack Mount Fiber Termination Unit, Optical Fiber Cable, 6U Rack with Cable Manager, PVC Channels etc. shall constitute the Award of Contract on the bidder.

20.0 PURCHASER'S RIGHT TO VARY QUANTITIES:

- 20.1 Purchaser will have the right to increase / decrease the fixed quantity items in the schedule of requirement up to 25% of the quantity of goods and services specified in the schedule of requirements without any change in the unit price of the ordered quantities or other terms and conditions at the time of award of the Purchase Order.
- 20.2 Number of the connections may increase or decrease by 25% at the time of execution.

21.0 DISQUALIFICATION OF BIDDER:

- 21.1 Purchaser reserves the right to disqualify the supplier for a suitable period who habitually failed to supply the equipment in time. Further, the suppliers whose equipment does not perform satisfactorily may also be disqualified for a suitable period as decided by the purchaser.
- 21.2 Purchaser reserves the right to blacklist a bidder for a suitable period in case he fails to honor his bid without sufficient grounds.
- 21.3 The bidder should give a certificate that none of his/her near relative is working in the units where he/she is going to apply for the tender, as per Annexure II. None of the near relative of proprietor OR all partners of partnership OR all the Directors of the company excluding Government of India/Financial institution nominees and independent non-Official part time Directors appointed by Govt. of India or the Governor of the state should be working in the unit where the tender is being applied. Due to any breach of these conditions by the company or firm or any other person the tender will be cancelled and Earnest Money Deposit will be forfeited at any stage whenever it is noticed and TEC will not pay any damage to the company or firm or the concerned person. The company or firm or the person will also be debarred for further participation in the concerned unit.
- The near relatives for this purpose are defined as:-
- a. Members of a Hindu undivided family.
 - b. They are husband and wife.
 - c. The one is related to the other in the manner as father, mother, son(s) & Son's wife (daughter in law), Daughter(s) and daughter's husband (son in law), brother(s) and brother's wife, sister(s) and sister's husband (brother in law).

SECTION - III

GENERAL (COMMERCIAL) CONDITIONS OF CONTRACT

1.0 APPLICATION:

The General Conditions shall apply in contracts made by the Purchaser for Supply, Installation and Commissioning of Passive LAN Infrastructure.

2.0 STANDARDS:

The Goods supplied under this contract shall conform to the requirements mentioned in Section V& special conditions in Section IV.

3.0 PATENT RIGHTS:

The Supplier shall indemnify the Purchaser against all third-party claims of infringement of patent, trademark or industrial design rights arising from use of the goods or any part thereof.

4.0 PERFORMANCE SECURITY:

- 4.1 The contractor shall furnish performance security to the purchaser for an amount equal to 10% of the contract value for the goods as prescribed in Advance Purchase Order within 15 days of issue of the Advance Purchase Order.
- 4.2 The proceeds of the performance security shall be payable to the purchaser as compensation for any loss resulting from the contractor's failure to complete its obligations under the contract.
- 4.3 The performance security may be submitted in the form of Term / Fixed deposit from scheduled Bank pledged in favour of ACCOUNTS OFFICER (Cash), TEC, New Delhi or in the form of a Performance Bank Guarantee (PBG) issued by a scheduled bank and in the Performa provided in Annexure III of this tender document.
- 4.4 The performance security shall remain valid for at least 3 Years 6 Months from the date of Advance Purchase Order. The performance security shall be renewed from time-to-time till all the liabilities of the supply of goods and its installation are resolved by the contractor.
- 4.5 In case, any amount of Liquidated Damages (L/D) is recovered from PBG, the Contractor shall replenish the PBG to original value within 30 days of recovery.
- 4.6 The purchaser will discharge the performance security, deducting the pending dues, liquidated damages, if any, after completion of the contractor's performance obligations including warranty obligations under the contract, and after furnishing of the Performance Bank Guarantee as per Clause No. 3 of Section IV.
- 4.7 No interest shall be paid on the performance security deposit amount.

5.0 INSPECTION AND TESTS:

- 5.1. The item on receipt by the ultimate consignee will be performance tested before *taking over* and if any equipment or part thereof is found defective, the same shall be replaced free of all cost to the purchaser as laid down in Clause 5.2 below.
- 5.2. If any equipment or any part thereof, before it is *taken over* under Clause 5.1 is found defective or fails to fulfil the requirements of the contract, the purchaser/ultimate consignee shall give the contractor notice, setting forth

details of such defects or failure and the contractor shall make the defective equipment good, or alter the same to make it comply with the requirements of the contract forthwith and in any case within a period not exceeding 21 days of the initial report. These replacements shall be made by the contractor free of all charges at site. Should it fail to do so within this time, the purchaser reserves the discretion to reject and replace at the cost of contractor, the whole or any portion of the equipment as the case may be, which is defective or fails to fulfil the requirements of the contract. The cost of any such replacement made by the purchaser shall be deducted from the amount payable to the Contractor.

- 5.3. When the performance tests called for have been successfully carried out, the ultimate consignee or its authorised representative will issue a *Taking over Certificate*, normally within six weeks of successful completion of tests. The ultimate consignee shall not delay the issue of any Taking Over Certificate contemplated by this clause, on account of minor defects in the equipment which do not materially affect the operational use thereof, provided that the Contractor shall undertake to make good the same in a time period not exceeding three months. BCPC (Bills Copy Payable Challan) shall be equivalent to "Taking over Certificate" from that consignee. "Taking over" of goods against the relevant phase of purchase order will be taken as complete only after all the BCPC have been received by the Purchaser.
- 5.4. Nothing in Clause 5as above shall in any way release the contractor from any warranty or other obligations under this contract.
- 5.5. Prospective bidder can inspect the TEC premises for assessing actual quantities of material required before submitting the bid. In case of deviation, instructions issued by TEC/designated authority shall be binding on the contractor.

6.0 DELIVERY:

- 6.1 Delivery of the goods and documents shall be made by the Contractor in accordance with the Schedule of Requirements (SOR) Section V and the special conditions of the contract (Section IV) and the goods shall remain at the risk of the contractor until delivery and installation has been completed in all respect. The delivery of the equipment shall be to the Ultimate Consignee as given in the purchase order.
- 6.2 The delivery of the goods and documents should be implemented strictly as per the delivery schedule as given below.
- a. Delivery of goods and documents – within 8 weeks of issue of Purchase Order.
 - b. Installation, system integration and documents – within 16 weeks of issue of Purchase Order.
 - c. Commissioning of the network – within 24 weeks of issue of Purchase Order.

7.0 WARRANTY:

- 7.1 The supplier shall warrant that the stores to be supplied shall be new and free from all defects and faults in materials used, workmanship and manufacture and shall be of the highest grade and consistent with the established and generally accepted standards for materials of the type ordered and shall perform in full conformity with the requirements and drawings as per

Annexure V. The supplier shall be responsible for any defect that may develop under the conditions provided by the contract and under proper use, arising from faulty material, design or workmanship such as corrosion of the equipment, inadequate quality of material to meet equipment requirements, inadequate contact protection, deficiencies in circuit design and/or otherwise and shall remedy such defects at his own cost when called upon to do so by the Purchaser who shall state in writing in what respect the stores are faulty. This warranty shall survive inspection or payment for / and acceptance of goods, but shall expire (except in respect of complaints notified prior to such date) 24 months after the last stores have been taken over under Clause 5.2 above.

7.2 If it becomes necessary for the Supplier to replace or renew any defective portion(s) of the equipment under this clause, the provisions of the Clause 5.3 shall apply to the portion(s) of the equipment so replaced or renewed or until the end of the above mentioned period of 24 months, whichever may be later. If any defect is not remedied by the supplier in accordance with clause 2.0 of Section IV within two weeks, the purchaser may proceed to get the defects remedied from other sources, at the supplier's risk and expenses, but without prejudice to any other rights which the purchaser may have against the supplier in respect of such defects including extension of warranty for delay beyond 2 weeks.

7.3 Replacement under warranty clause shall be made by the supplier free of all charges at site including freight, insurance and other incidental charges.

8.0 PAYMENT TERMS:

8.1 70% Cost of the goods supplied in a purchase order will be paid on receipt of the goods in good condition, at site after conformity checks. For claiming this payment following documents must be produced.

- a. Bills in duplicate duly pre-receipted
- b. Delivery Challan
- c. Excise gate pass and/or Custom Duty Paid Certificate or equivalent document as applicable.
- d. Certificates of receipt of goods in physically good condition from the ultimate consignees.
- e. Proof of payment of Octroi / Entry tax etc., if any
- f. Invoice countersigned by officer-in-charge.
- g. Consignee receipt on Delivery Challan.

8.2 Bills for the supply of total quantity of a purchase order of complete supply will be settled once, on submission of the documents as mentioned above.

8.3 20% of the cost of the goods supplied in the purchase order and 90% Cost of the Installation and removal of old cables will be paid on taking over the network. For claiming this payment following documents must be produced

- a. Invoice countersigned by officer-in-charge
- b. Taking over Certificate from ultimate consignee.

8.4 The balance 10% of the total purchase order cost shall be released after 6 months from "Taking Over" as per clause 5.3 of Section III subject to production of certificate of satisfactory performance from designated officer in-charge of the ultimate consignees.

8.5 Payment to the bidder shall be made on the basis of actual CAT-6 cable, optical fiber cable, Patch Cords, Patch Panel, PVC ducts, PVC channels, flexible pipe laid and actual number of computer (RJ 45 / I/O box) connections installed / provided.

8.6 Deductions of liquidated damages, if any, shall be made from the relevant bill.

9.0 PRICES:

9.1 The accepted prices shall remain valid and operative during currency of the contract.

9.2 Prices charged by the contractor for the services performed under the contract shall not be higher than the prices quoted by the contractor in his Bid.

9.3 Prices for services once fixed will remain valid for the currency of the contract. However, increase/decrease only in the rates of statutory levies/taxes by the Government, during the original delivery period will be allowed.

9.4 The benefit arising out of reduction in rates of taxes/levies by the Government before the supplies made, will be passed on to purchaser.

10.0 SUB-CONTRACTS:

No subcontracts are permitted.

11.0 DELAYS IN THE SUPPLIER'S PERFORMANCE:

11.1 Delivery of the Goods and performance of the services shall be made by the Supplier in accordance with the time schedule specified by the purchaser in its purchase order. In case the supply is not completed within the stipulated delivery period, as indicated in the Purchase Order, purchaser reserves the right to short close/cancel this purchase order and/or recover liquidated damage charges. The cancellation/short closing of the order shall be at the risk and responsibility of the supplier and purchaser reserves the right to purchase balance unsupplied item at the risk and cost of the defaulting suppliers.

11.2 Delay by the Supplier in the performance of its delivery and warranty obligations shall render the Supplier liable to any or all of the following sanctions, viz., imposition of liquidated damages, and forfeiture of its performance security and/or termination of the contract for default.

11.3 If at any time during the performance of the contract, the supplier encounters condition impeding timely delivery of the goods and performance of service, the Supplier shall promptly notify to the Purchaser in writing the fact of the delay, its likely duration and its cause(s). As soon as practicable after receipt of the supplier's notice, the Purchaser shall evaluate the situation and may at its discretion extend the period for performance of the contract subject to furnishing of additional performance security by the supplier @ 5% of the total contract value.

11.4 If the supplies are not completed in the extended delivery period, the purchase order may be short-closed and the Performance security shall be forfeited. However, in such situation the supplier will have to furnish a fresh performance security of 10% of the Purchase Order value for the quantity supplied.

12.0 LIQUIDATED DAMAGES:

12.1 The date of delivery of the stores stipulated in the acceptance of the tender should be deemed to be the essence of the contract and delivery must be

completed no later than the dates specified therein. Extension will not be given except in exceptional circumstances. Should, however, deliveries be made after expiry of the contracted delivery period, without prior concurrence of the purchaser and be accepted by the consignee, such delivery will not deprive the purchaser of his right to recover liquidated damage under Clause 12.2 below.

- 12.2 However, when the goods are supplied within 7 days of the original delivery period, consignee may accept the goods. In such cases the provisions of clause 12.1 shall not be applicable, and no liquidated damages shall be leviable.
- 12.3 Should the supplier fails to deliver the store or any consignment thereof within the period prescribed for delivery, the purchaser shall be entitled to recover 0.5 % of the value of the delayed supply for each week of delay or part thereof for a period up to 10 (TEN) weeks and thereafter at the rate of 1% of the value of the delayed supply for each week of delay or part thereof, subject to a maximum 10% of the total value of the concerned purchase order. Quantum of liquidated damages assessed and levied by the purchaser shall be final and not challengeable by the supplier.
- 12.4 Goods rejected on receipt of supply shall also be subjected to LD charges if not replaced within the stipulated delivery period as such supply shall be taken as non-supply.
- 12.5 The payment of LD shall not in any way relieve the contractor from any of its obligation/ liabilities to make supplies of services/ goods under the contract.

13.0 FORCE MAJEURE:

- 13.1 If, at any time, during the continuance of this contract, the performance in whole or in part by either party of any obligation under this contract is prevented or delayed by reasons of any war or hostility, acts of the public enemy, civil commotion, sabotage, fires, floods, explosions, epidemics, quarantine restrictions, strikes, lockouts or act of God (hereinafter referred to as events) provided notice of happenings of any such eventuality is given by either party to the other within 21 days from the date of occurrence thereof, neither party shall by reason of such event be entitled to terminate this contract nor shall either party have any claim for damages against other in respect of such non-performance or delay in performance, and deliveries under the contract shall be resumed as soon as practicable after such an event come to an end or cease to exist, and the decision of the Purchaser as to whether the deliveries have been so resumed or not shall be final and conclusive. Further that if the performance in whole or part of any obligation under this contract is prevented or delayed by reasons of any such event for a period exceeding 60 days, either party may, at its option, terminate the contract.
- 13.2 Provided, also that if the contract is terminated under this clause, the purchaser shall be at liberty to take over from the supplier at a price to be fixed by the purchaser, which shall be final, all unused, undamaged and acceptable materials, bought out components and stores in course of manufacture which may be in possession of the supplier at the time of such termination or such portion thereof as the purchaser may deem fit, except

such materials, bought out components and stores as the supplier may elect to retain with the concurrence of the purchaser.

14.0 TERMINATION FOR DEFAULT:

- 14.1 The Purchaser may, without prejudice to any other remedy for breach of contract, by written notice of default, sent to the supplier, terminate this contract in whole or in part
- a. If the supplier fails to deliver any or all of the goods within the time period(s) specified in the contract, or any extension thereof granted by the purchaser pursuant to Clause 6 and 11 of this section.
 - b. if the supplier fails/delays to perform any other obligation(s) under the contract; and
 - c. If the supplier, in either of the above circumstances, does not remedy his failure within a period of 15 days (or such longer period as the purchaser may authorize in writing) after receipt of the default notice from the purchaser.
- 14.2 In the event the purchaser terminates the contract in whole or in part pursuant to Clause 14.1, the purchaser may procure, upon such terms and in such manner as it deems appropriate, goods similar to those undelivered and the supplier shall be liable to the purchaser for any excess cost for such similar goods. However, the supplier shall continue the performance of the contract, including warranty, to the extent not terminated.
- 14.3 The purchaser reserves the right to ban a contractor to quote in further tender enquiries for a specified period, in case he fails to honor his bid/contractual obligations, without sufficient and reasonable grounds.

15.0 TERMINATION FOR INSOLVENCY:

The Purchaser may at any time terminate the contract by giving written notice to the supplier, without compensation to the supplier, if the supplier becomes bankrupt or otherwise insolvent as declared by the competent court provided that such termination will not prejudice or affect any right of action or remedy which has accrued or will accrue thereafter to the purchaser.

16.0 ARBITRATION:

- 16.1 In the event of any dispute or difference arising as to the execution of the contract or as to the respective rights or liabilities of the parties or the interpretation of any condition of agreement (except as to any matters the decision of which is specially provided for any by those or the special conditions) the same shall be referred to the sole arbitration of Sr. DDG, TEC, New Delhi or of his nominee. If the post of Sr. DDG, TEC is vacant, a higher authority or his nominee will act as Sole Arbitrator. The award of the arbitrator shall be final and binding on the parties to the agreement.
- 16.2 The arbitrator may from time to time with the consent of the parties to the agreement enlarge the time for making the award.
- 16.3 Upon every such reference, the assessment of the cost incidental to the reference and award respectively shall be the discretion of the arbitrator.
- 16.4 The agreement to appoint an arbitrator will be in accordance with the Arbitration and Conciliation Act. 1996.
- 16.5 In the event of such arbitrator to whom the matter is originally referred, being transferred or vacating his office or being unable to act for any reasons whatsoever another person shall be appointed to act as arbitrator by

Department of Telecom in accordance with terms of agreement and person so appointed shall be entitled to proceed from the stage at which it was left out by his predecessors.

- 16.6 The venue of arbitration shall be New Delhi the place from which the acceptance note is issued or such other places, as the Sr. DDG, TEC at his discretion may determine. In this clause, the terms Sr. DDG, TEC includes any other officer who is for the time being discharging the duties of Sr. DDG, TEC, whether in addition to other functions or otherwise.

17.0 SET OFF:

Any sum of money payable to the Contractor (including security deposit refundable to him) under this contract may be appropriated by the purchaser or the purchasers or any other person or persons contracting through the purchaser and set off the same against any claim of the purchaser or purchaser or such other person or persons for payment of sum of money arising out of this contract or under any other contract made by the Contractor with purchaser of the purchaser or such other person or persons contracting through the purchaser.

18.0 COURT JURISDICTION AND INTERPRETATION OF CONTRACT:

This Contract/e PO is subject to jurisdiction of the competent Courts at New Delhi only. This Contract shall be interpreted in accordance with Indian Law.

19.0 PAYMENT METHOD:

- 19.1 Payment shall be made to the contractor electronically or through cheque for which a supplier shall provide the necessary details of his bank account.
- 19.2 Income Tax or any other applicable taxes shall be deducted at source at the time of payment to the contractor, in accordance with the provisions of the relevant applicable Acts.

20.0 PAYING AUTHORITY:

Sr. DDG (TEC), New Delhi shall be the paying authority for supply of goods and disbursing authority shall be ACAO (Cash), TEC .

21.0 Consignee:

ADG (AS), Telecom Engineering Centre, Gate No. 5, K.L. Bhawan, Janpath, New Delhi or the authority designated by the purchaser shall be the consignee for receipt of material, however Reporting/Controlling Officer for complete project under this tender will be "IT" division or the authority designated by the purchaser.

SECTION - IV

SPECIAL CONDITIONS OF CONTRACT

1.0 The special conditions of contract shall supplement the 'Instructions to the Bidders' as contained in Section II & "General (Commercial) Conditions of the Contract" as contained in Section III and wherever there is a conflict, the provisions herein shall prevail over those in Section II and Section III. If there is any discrepancy in NIT published in newspapers and eligibility, terms & conditions stipulated in tender document, provision in the tender documents shall prevail.

For interpretation of any condition of this tender document, the decision of Purchaser shall be final and binding on the Bidder.

2.0 SCHEDULE OF WORK/ SCOPE OF WORK:

2.1 Structured LAN cabling:

2.1.1 The work shall broadly include:

- a. Integration of new network elements such as switches and routers being installed by CDOT.
- b. Integration of the existing LAN Switches, to the extent required. A schematic of the LAN is enclosed in Annexure V. The OF cable connectivity, fibre connectivity and the floor wise connectivity are also shown. The actual location of the switches, nodes, Fibre Termination Unit(FTUs) shall be decided by TEC at the time of execution.
- c. The contractor shall submit the initial plan of laying the Fibre/CAT6 cable network to TEC after detailed survey of the building. The purchaser may suggest minor modifications in the laying plan during the execution and the contractor shall carry out these modifications. All the cables shall be laid as per the approved plan.
- d. All unused cables/cable trays/other passive components currently in use shall be dismantled and removed after commissioning of the new passive network. These cables shall be recovered and disposed by the contractor after the fibre connectivity and LAN connectivity is successfully completed. All the unused older LAN cables are to be removed priorly for facilitating the new cable installation. The contractor is required to remove the false flooring/roofing and remove/install the OF/LAN cables. After the installation work is completed, the false flooring/roofing is to be restored without any damage. The contractor is required to lay these cables through the cable raisers between the floors.
- e. Identification of existing cable runs and equipment port connectivity charts shall be prepared and submitted (both hard copy and soft copy) by the contractor.
- f. Tags shall be fixed at the both ends of every cable identifying the cable path and cable ends (both for fibre and for Cat6 Cable) as per the labelling plan for cabling infrastructure.
- g. Marking and identification of entire LAN infrastructure. The floor wise plan of cable laying shall be submitted (both hard copy and soft copy).
- h. Creation of separate cable trays/pathways/raceways wherever required. The OF cables and LAN cables shall be laid through the PVC pipes. The ends of the

- PVC pipes shall be closed properly for avoiding the rat entry. All pipe end points shall properly closed.
- i. Documentation required to be handed over to building administration for ease of maintenance of cabling infrastructure.
 - j. LAN cables on each floor shall be terminated into required numbers of termination boxes/telecommunication closets before the same are extended to the individual computers/hosts.
 - k. The LAN infrastructure coverage area shall cover the whole of TEC.
 - l. The wired LAN/Fibre infrastructure shall be installed without affecting the existing network connectivity of individual computers/hosts and existing other infrastructure such as power cabling/Wi-Fi cabling.
 - m. The multimode/Single mode fibre connectivity from the central Fibre Port Switch to the individual floor LAN Switches shall be taken through two separate routes and terminated in the fibre termination boxes near the Floor LAN switches
 - n. The Fibre termination units, LIU for fibre termination and/or Fibre Distribution Frames shall be equipped with SC-PC type '0'dB adapters.
 - o. After passive cabling installation work is completed, the commissioning of this network shall be declared by TEC in consultation with CDOT.
 - p. Four OF cables shall be terminated in the 2nd floor of TEC. Two OF cables shall be laid towards 2nd floor, 1st floor and Ground floor. Two more OF cables shall be laid towards 3rd floor, 4th floor, fifth floor and sixth floor.
 - q. The bidder shall measure and submit the optical power levels/attenuation for each fibre in the four cables. The OTDR trace showing the continuity for the both side terminated fibres/cables shall be submitted by the contractor.
 - r. The contractor shall be required to work in coordination with CDOT personnel for successful commissioning of the Switches and routers. Necessary operational support required in tracing the installed fibres/CAT 6 cables shall be extended to CDOT. In case CDOT confirms that the fibre/CAT 6 connectivity is not established, the contractor shall restore the fault immediately.
 - s. After CDOT confirms that all the network elements (switches) are connected on two fibre paths, the fibre cabling part is considered as completed.
 - t. After the designated officer of TEC confirms that all the user nodes (computers) are connected in the LAN and internet is accessible on these nodes then the CAT 6 cable network shall be considered as completed.
 - u. The unused material (in SOR) shall be handed over to IT division. The optical power meter shall be handed over to IT division.
 - v. The final fibre connectivity plan and CAT6 connectivity plan shall be submitted by the contractor (both hard copy and soft copy).
 - w. The patch cords at SI no 15,16,17 of the SOR shall be factory made.
 - x. The CAT6 connectors shall be crimped firmly to the CAT6 cable. The CAT6 cable jacket shall be firmly held by the connector.

3.0 SUPPLIER'S RESPONSIBILITIES:

The responsibility of the Supplier shall be as follows:

- a. Supply/Delivery of the items mentioned in clause 1.0 of SOR in Section V, Installation and Commissioning as per clause 1.1 of SOR in Section V.
- b. The Supplier shall provide fireproof wiring.
- c. Completion of the work as per the scope at Clause 2.0 of Section IV.

4.0 ROLE OF PURCHASER:

Role of Purchaser shall be to provide the following:

- a. Space for installation of cable in purchaser building.
- b. Facilities like alternating current (AC) electric power.
- c. Declaration of the commissioning of the LAN network.

5.0 INSTALLATION & COMMISSIONING:

- 5.1 Installation of passive network shall be done as described in scope of work. Commissioning of passive network shall be completed within specified period as described in Para 6 of section III.

6.0 OTHER CONDITIONS:

- 6.1 The quality of goods & services should strictly be as per specification mentioned at Section-V and in Clause no. 2, 3 & 5 above.
- 6.2 Quality checking will be done by the Reporting/Controlling/Designated Officer. No payment shall be made for the goods or services rejected due to deficient quality.
- 6.3 All the responsibilities of getting support from third parties for spare/services shall be with the Contractor. Purchaser shall not have any obligation to contact such third parties.
- 6.4 After expiry of the contract all the network items are to be handed over to Purchaser within five working days of expiry of contract in full working condition and a certificate to effect is required to be obtained by the vendor from concerned officer in charge of the maintenance and to produce along with the final claim.
- 6.5 The contractor shall also provide his contact phone number to the purchaser which should be responded 24*7, so that he may be approached in case of any requirement.
- 6.6 The personnel deployed by the contractor for the job shall be medically fit and possess good conduct and be amenable to discipline.
- 6.7 On repeated defaults, the contract is liable to be cancelled at the risk and cost of the Contractor.
- 6.8 No hindrance shall be caused by the contractor or his workforce to the purchaser's staff/work.
- 6.9 All employees of the contractor shall be employees of the Contractor and shall remain so. Purchaser will not have any liability to absorb them at any point of time, nor can the employees of contractor claim any right for employment in TEC.
- 6.10 Payment of all kinds of Government taxes or duties will be the liability of the contractor.
- 6.11 The contractor shall abide with all local/municipal/state/central/labour laws provisions including payment of minimum wages as declared by Central Government or State Government whichever is higher and regulations.
- 6.12 Any liability under any act or statute shall be of the contractor and under no circumstances shall purchaser assume responsibility.
- 6.13 If any of the persons engaged by the contractor is not working satisfactorily or misbehaves with any of the officials of the purchaser, the contractor shall

replace him immediately. In case the purchaser feels that the working/conduct of any of contractor's employees is detrimental to the interests of the purchaser, it shall have unqualified right to request for the removal of such employee for incompetence, unreliability, misbehavior, security reasons, etc., while on or off the job. The contractor shall comply with any such request to remove such personnel at his own expense unconditionally. The contractor will be allowed a maximum of two working days to replace the person by competent qualified person.

6.14 The contractor shall submit a letter mentioning the details of the Resident Professional along with their relevant certificates deployed in TEC under this contract, to Reporting/Controlling Officer.

6.15 The contractor shall provide necessary insurance coverage to his workmen, keeping in view the scope of work and material to be handled by them, so as to indemnify the purchaser for any act from contractor's workmen in case of any accident, or mishap, including death. The insurance cost of personnel working for the contractor at the site, shall be borne by the contractor.

7.0 SIGNING OF TENDER DOCUMENT BY BOTH PARTIES

Each page of this tender document may be signed by both the parties and kept on the record to serve as contract after submitting the PBG.

Section - V

SCHEDULE OF REQUIREMENTS

1.0 SUPPLY ITEMS FOR PASSIVE COMPONENTS (STRUCTURED CAT-6 CABLING):

1. (*)	Structure CAT-6 cable (@30 m / computer)(305mt /Box)	16 Boxes
2.	Patch Panel 24 Port with Loaded IO Modules	12
3.	Patch Cord 1mt Cat-6 (From switch to Patch Panel)	200
4.	Patch Cord 2mt Cat-6 (From IO Box to PC)	150
5.	Information Outlet [IO] Boxes with one RJ45 [Telecommunications Outlet]	250
6.	4 fibre LIU for Fiber Termination (with SC-PC '0'dB adapters)	12
7.	24 Fibre Rack Mount Fiber Termination Unit (with SC-PC '0'dB adapters)	4
8. (@)	Optical Fiber Cable (High End to Low End LAN Switch) (Single Mode Band insensitive Fiber, 24 Fiber/Cable)	400mt
9.	9U Rack with Cable Manager for Housing LAN Switch, Patch Panel, LIU and Cable terminations	8
10. (@)	PVC Channel 1"	800mt
11. (@)	PVC Duct 2"	1000mt
12. (@)	PVC Flexible Pipe 1"	300mt
13.	Pigtail with SCPC Connector 1 mt (for termination of fibre in Fibre termination unit)	192
14.	Patch Cord (Switch to Patch Panel) (Both Sides SC-PC) 1 mt	40
15.	Cat 6 Patch Cord (Patch Panel to router) 5 mt	50
16.	Cat 6 Patch Cord (Patch Panel to Patch panel for maintenance) 10 mt	5
17. (@)	Cat 6 Patch Cord (Patch Panel to Patch panel for maintenance) 20mt	5
18	Optical power meter (1310nm, 1550nm) with two SC-PC and two LC-PC adapters/Patch cords	1

1.1 EXECUTION ACTIVITIES:

1. #	Installation and commissioning charges for the Structured LAN cabling for 150 Nodes	
2. \$	Removal of existing UTP cabling	

@=The quantities are for evaluation purpose and payment shall be based on the actual quantity used.

* = Average length of cabling per computer is approx. 30 meters and can increase or decrease for each computer connection depending on its distance from the switch. This figure has been mentioned for the purpose of evaluation of bid.

= Numbers of connections have been mentioned for the purpose of evaluation of the bid. Numbers of connections may increase or decrease by 25% at time of execution.

\$ =The bidder shall quote a lump sum amount for removal of existing UTP cabling.

Section – V-A

PRICE SCHEDULE FOR BILL OF REQUIREMENTS

COST OF SUPPLY OF GOODS ITEMS FOR PASSIVE COMPONENTS INCLUDING STRUCTURED CAT-6 CABLING:

Sl.No.	Items description	Quantity (A)	Unit Rate (B)	Total C=(A*B)	Tax in Rs D	Total Cost C+D
1.	Structure CAT-6 cable (@30 m / computer)(305mt /Box)	16 Boxes				
2.	Patch Panel 24 Port with Loaded IO Modules	12				
3.	Patch Cord 1mt Cat-6 (From switch to Patch Panel)	200				
4.	Patch Cord 2mt Cat-6 (From IO Box to PC)	150				
5.	Information Outlet [IO] Boxes with one RJ45 [Telecommunications Outlet]	250				
6.	4 fibre LIU for Fiber Termination (with SC-PC '0'dB adapters)	12				
7.	24 Fibre Rack Mount Fiber Termination Unit (with SC-PC '0'dB adapters)	4				
8.	Optical Fiber Cable (High End to Low End LAN Switch) (Single Mode Band insensitive Fiber, 24 Fiber/Cable)	400mt				
9.	9U Rack with Cable Manager for Housing LAN Switch, Patch Panel, LIU and Cable terminations	8				
10.	PVC Channel 1"	800mt				
11.	PVC Duct 2"	1000mt				
12.	PVC Flexible Pipe 1"	300mt				
13.	Pigtail with SCPC Connector 1 mt (for termination of fibre in Fibre termination unit)	192				
14.	Patch Cord (Switch to Patch Panel) (Both Sides SC-PC) 1 mt	40				
15.	Cat 6 Patch Cord (Patch Panel to router) 5 mt	50				
16.	Cat 6 Patch Cord (Patch Panel to Patch panel for maintenance) 10 mt	5				
17.	Cat 6 Patch Cord (Patch Panel to Patch panel for maintenance)20mt	5				
18.	Optical power meter (1310nm, 1550nm) with two SC-PC and two LC-PC adoptions/Patch cords	1				

19.	Installation and commissioning charges for the Structured LAN cabling for 150 Nodes					
20.	Removal of existing UTP cabling					
Grand Total in Rs						

ANNEXURE - I PROFILE OF BIDDER

1. Full Name of Bidder
2. Registered Address

3. Address of correspondence

4. Details of Contact/Authorized Person
Name & Designation _____
Address _____
Tel No. (Landline) _____ Mobile _____
Email ID _____ FAX: _____
5. Type of Firm: Private Ltd./Public Ltd./Co-operative/PSU/Proprietary
(Please tick the appropriate)
6. Name(s) of Directors/ partners/ proprietor

7. PAN/GIR No. : _____

8. TIN No. : _____

9. Service Tax Registration No. : _____

10. Proof of Annual Turnover of :

11. Earnest money details: DD No. _____ dated _____ for
Rs..... drawn on _____
12. Bank Account details of the bidder:
 - a. Name and address of Bank
 - b. Account no.
 - c. MICR no.
 - d. IFSC code of Branch
13. Any other relevant information:

(Signatures of authorized signatory)
Name _____
Designation _____
Seal:

ANNEXURE - II

NO NEAR-RELATIVE DECLARATION/CERTIFICATE

(To be submitted by either authorized signatory or proprietor, or each partner/director
in case of partnership firms/companies)

I _____ son/daughter/wife of Shri _____
_____ Proprietor
/Partner/Director/Authorised signatory/Representative of M/s _____

(Name and address of the bidder) is competent to sign this declaration and execute the tender document regarding "Supply, Installation and Commissioning of Passive LAN Infrastructure at Telecom Engineering Centre at Khurshid Lal Bhawan, Janpath, New Delhi";

I _____ resident of _____ hereby certify that none of relatives of mine/proprietor/partners/directors is/are employed in the units where he/she is going to apply for the tender. In case at any stage it is found that the information given by me is false/incorrect the purchaser shall have the absolute right to take any action as deemed fit/without any prior information to me.

I have carefully read and understood all the terms and conditions of the tender document and undertake to abide by the same;

I also undertake that our firm will observe all legal formalities or/and obligations under the contract well within time. In case of failure to observe any of the legal formalities or/and obligations. I shall be personally liable under the appropriate law.

The Information/documents furnished, along with the tender document are true and authentic to the best of my knowledge and belief. I am well aware of the fact that furnishing of any false information/fabricated documents would lead to rejection of my tender at any stage besides liabilities towards prosecution under appropriate law.

(Signature of Proprietor/Partners/Director/Authorized Signatory)

Date:

Place:

Full Name:

Address:

Seal:

ANNEXURE - III

PERFORMANCE SECURITY BOND FORM

In consideration of the President of India (hereinafter called 'the Government') having agreed to exempt ----- (hereinafter called 'the said Contractor(s)') from the demand, under the terms and conditions of an agreement / (Purchase Order) No. ----- Dated ----- made between ----- and ----- for the supply of ----- (hereinafter called 'the said Agreement'), of performance security for the due fulfilment by the said Contractor(s) of the terms and conditions contained in the said Agreement, on Production of a bank guarantee for ----- we, (Name of the bank) ----- (hereinafter referred to as 'the Bank') at the request of -----contractor(s) do hereby undertake to pay to the TEC an amount not exceeding ----- against any loss or damage caused to or suffered or would be caused to or suffered by the TEC by reason of any breach by the said Contractor(S) of any of the terms or conditions contained in the said Agreement.

2. We (Name of the bank) ----- do hereby undertake to pay the amount due and payable under this guarantee without any demur, merely on a demand from the TEC stating that the amount claimed is due by way of loss or damage caused to or would be caused to or suffered by the TEC by reason of the contractor(s) failure to perform the said Agreement. Any such demand made on the bank shall be conclusive as regards the amount due and payable by the Bank under this guarantee where the decision of the TEC in these counts shall be final and binding on the bank. However, our Liability under this guarantee shall be restricted to an amount not exceeding -----.

The Bank further agrees that the guarantee herein contained shall remain in full force and effect for a period of 3 Years 6 Months from the date hereof and also that the extension of this guarantee will be provided for by the Bank for such period beyond the period of 3 Years 6 Months as the Purchaser may feel necessary in this behalf.

3. We undertake to pay to the TEC any money so demanded notwithstanding any dispute or disputes raised by the contractor(s)/ supplier(s) in any suit or proceeding pending before any court or tribunal relating thereto our liability under this present being absolute and unequivocal. The payment so made by us under this bond shall be valid discharge of our liability for payment there under and the contractor(s)/ supplier(s) shall have no claim against us for making such payment.
4. We (name of the bank) ----- Further agree that the guarantee herein contained shall remain in full force and effect during for a period of 3 Years 6 Months from the date of Advance Purchase Order (Date.....). And that it shall continue to be enforceable till all the dues of the TEC under or by virtue of the said Agreement have been fully paid and its claims satisfied or discharged or till ----- (TEC) certifies that the terms and conditions of

the said Agreement have been fully and properly carried out by the said contractor(S) and accordingly discharge this guarantee.

- 5. We (Name of the bank) ----- further agree with the TEC that the TEC shall have the fullest liberty without our consent and without affecting in any manner our obligations hereunder to vary and of the terms and conditions of the said Agreement or to extend time of performance by the said contract(s) from time to time or to postpone for any time or from time to time any of the powers exercisable by the TEC Against and said Contract(s) and to forbear or enforce any of the terms and conditions relating to the said agreement and we shall not be relieved from our liability by reason of any such variation, or extension being granted to the said Contract(s) or for any forbearance, act or omission on the part of the TEC or any indulgence by the TEC to the said contract(s) or by any such matter or thing whatsoever which under the law relating to sureties would, but for this provision, have effect of so relieving us.
- 6. This guarantee will not be discharged due to the change in the constitution of the Bank or the contractor(s)/ supplier(s).
- 7. We (name of the bank) ----- lastly undertake not to revoke this guarantee during its currency except with the previous consent of the TEC in writing.

Dated the ----- day of -----, Two Thousand Fifteen only.

For -----
(Indicate the name of the bank)

Witnesses: (Name & Signature)

1.

Telephone No.(s):-
STD Code-
FAX No.
E-Mail Address:-

2.

ANNEXURE - IV BID FORM

Tender No. 2-14/2019-MM/TEC

DatedXX.XX.2019

Sr. DDG (TEC),
Telecom Engineering Centre,
K.L. Bhawan, Janpath, New Delhi 110001.

Dear Sir,

Having examined the conditions of tender and specifications including clarifications/addenda the receipt of which is hereby duly acknowledged, we, the undersigned, offer to supply and deliver the items quoted in Price Schedule of this bid document in conformity with said conditions of contract and specifications for a sum of amount as quoted in Price Schedule or such other sums as may be ascertained in accordance with the schedule of prices attached herewith and made part of this Bid.

We undertake, if our Bid is accepted, to commence and complete deliveries as prescribed in the tender document. We also undertake to indemnify purchaser and user against all third party claims of infringement of patent, trademark or industrial design rights arising from use of the goods or any part thereof, supplied against the tender. Further we also undertake to indemnify the purchaser and user in respect of any damages, claims, loss or action against purchaser and user for acts of commission or omission on our part or on the part of our agents or servants.

If our Bid is accepted, we will obtain and provide to TEC the guarantees of a Scheduled Bank for a sum not exceeding 10% of the contract sum for the due performance of the Contract.

We agree to abide by this Bid for a period of 180 days from the date fixed for Bid opening and it shall remain binding upon us and may be accepted at any time before the expiration of that period.

Bid submitted by us is properly prepared and protected so as to prevent any subsequent alteration and replacement.

We understand that you are not bound to accept the lowest or any bid, you may receive.

Dated thisday of2019

(.....)
Signature of.....

in capacity of.....
(Duly authorized to sign the bid for and on behalf of.....)

Witness.....

Tele No.(s):-

Signature.....

FAX No.(s):-

Address.....

E-Mail Address:-

ANNEXURE - V

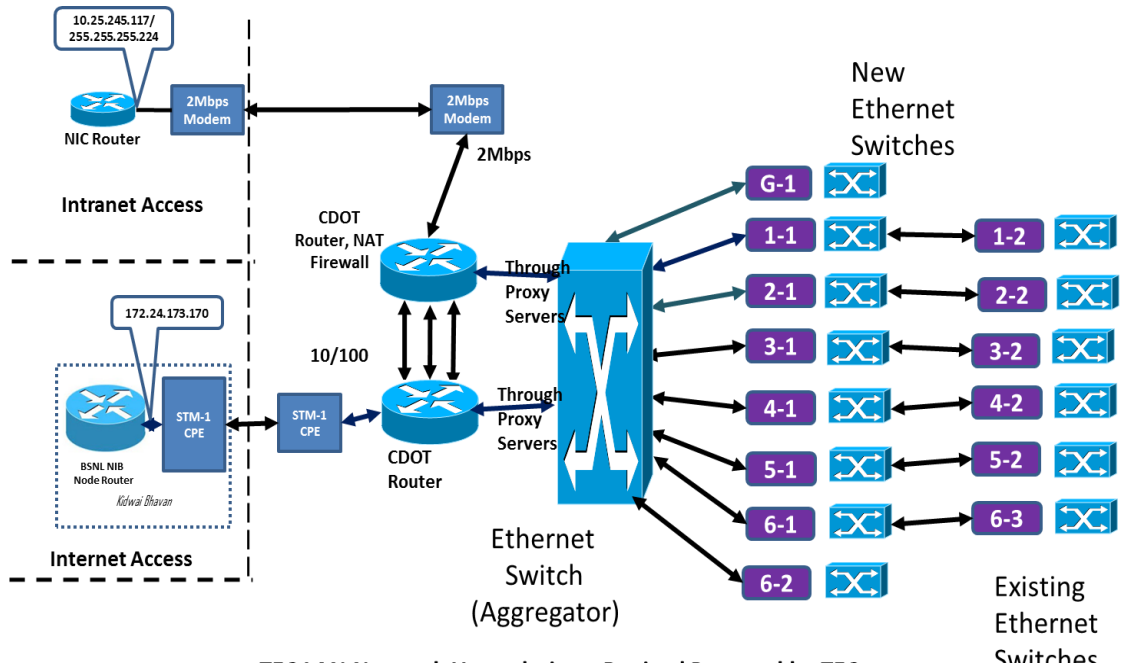

Figure 1: Proposed LAN upgradation Network diagram

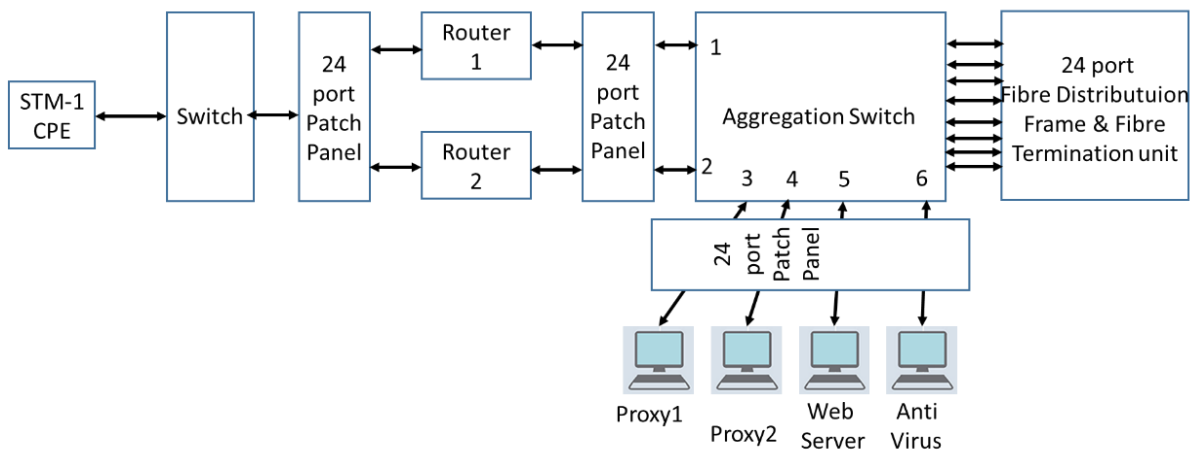

Figure 2: Network block diagram of Router, STM CPE and Aggregation Switch

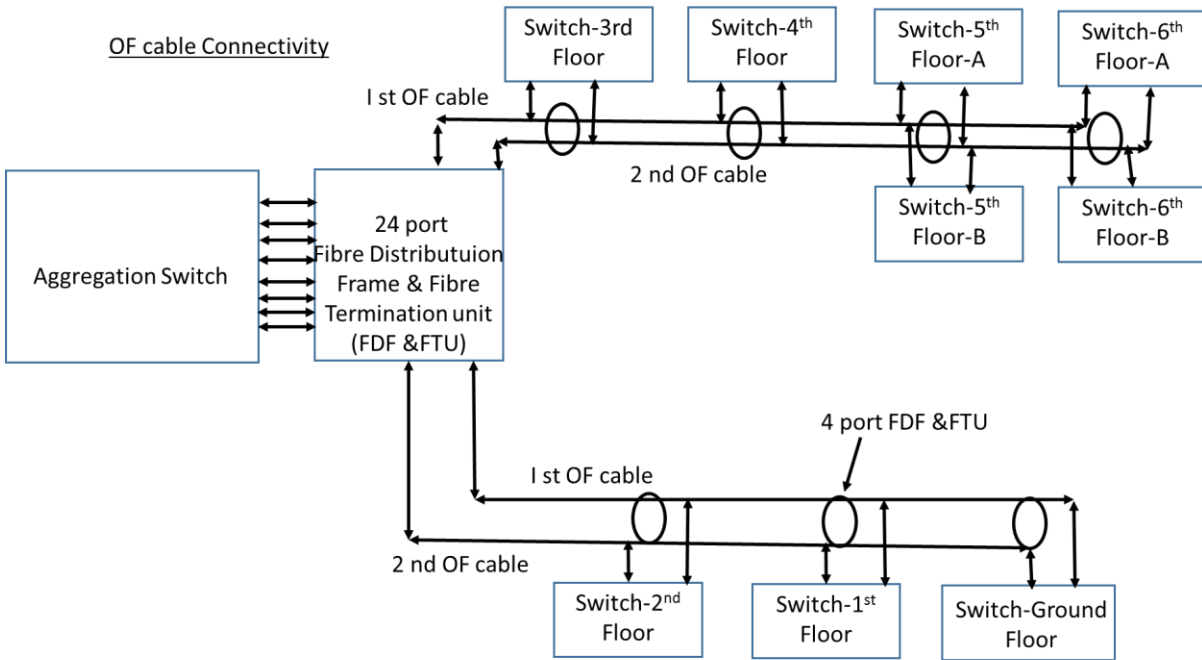

Figure 3: Optical fiber cable connectivity from aggregation switch to switch on each floor

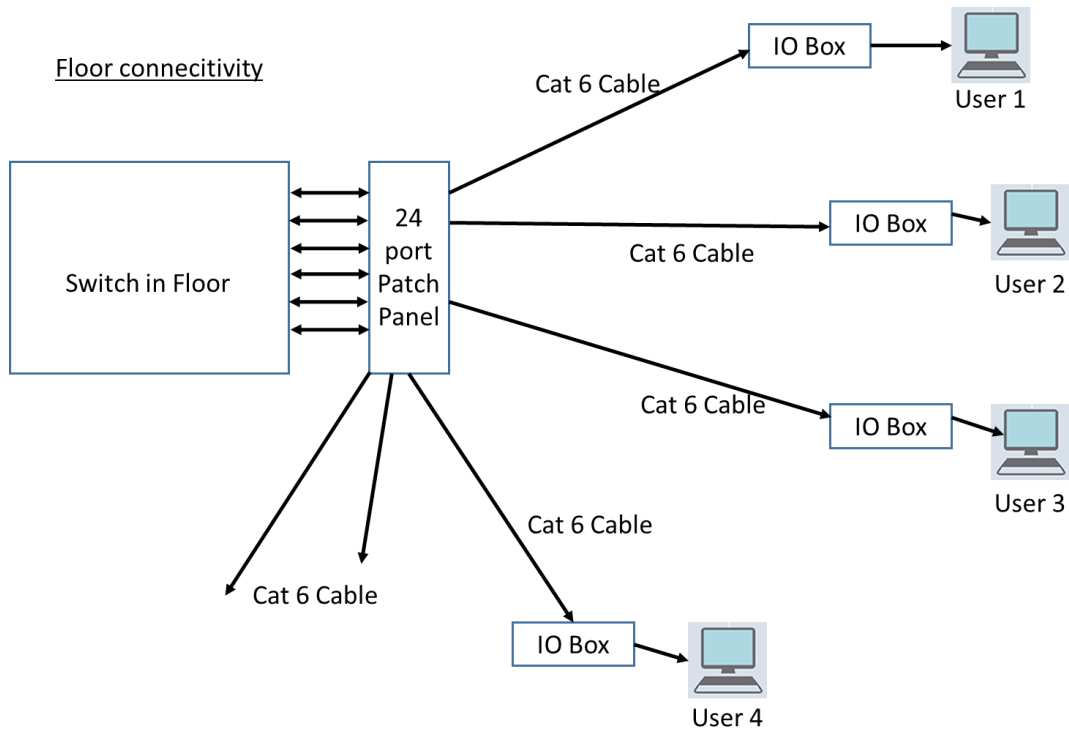

Figure 4: Floor connectivity diagram of CAT6 cable to user system from Switch on each floor