



वर्गीय आवश्यकताओं के लिए मानक
टीईसी ५७०६०:२०२४

STANDARD FOR GENERIC REQUIREMENTS

TEC 57060:2024

अल्ट्रा हाई डेफिनिशन (यूएचडी) और आभासी वास्तविकता
के साथ हाइब्रिड सेट टॉप बॉक्स (एसटीबी)

HYBRID SET TOP BOX (STB) WITH SUPPORT FOR
ULTRA HIGH DEFINITION (UHD) & VIRTUAL
REALITY



ISO 9001:2015

दूरसंचार अभियांत्रिकी केंद्र

दूरसंचार विभाग, संचार मंत्रालय, भारत सरकार

खुरशीदलाल भवन, जनपथ, नई दिल्ली-११०००१, भारत

TELECOMMUNICATION ENGINEERING CENTRE

DEPARTMENT OF TELECOMMUNICATIONS, MINISTRY OF COMMUNICATIONS

GOVERNMENT OF INDIA, KHURSHIDLAL BHAWAN, JANPATH, NEW DELHI-110001, INDIA

www.tec.gov.in

© टीईसी, २०२४

© TEC, 2024

इस सर्वाधिकार सुरक्षित प्रकाशन का कोई भी हिस्सा, दूरसंचार अभियांत्रिकी केंद्र, नई दिल्ली की लिखित स्वीकृति के बिना, किसी भी रूप में या किसी भी प्रकार से जैसे -इलेक्ट्रॉनिक, मैकेनिकल, फोटोकॉपी, रिकॉर्डिंग, स्कैनिंग आदि रूप में प्रेषित, संग्रहीत या पुनरुत्पादित न किया जाए ।

All rights reserved and no part of this publication may be reproduced, stored in a retrieval system or transmitted, in any form and by any means - electronic, mechanical, photocopying, recording, scanning or otherwise, without written permission from the Telecommunication Engineering Centre, New Delhi.

Release: March, 2024

FOREWORD

Telecommunication Engineering Centre (TEC) is the technical arm of Department of Telecommunications (DOT), Government of India. Its activities include:

- Framing of TEC Standards for Generic Requirements for a Product/Equipment, Standards for Interface Requirements for a Product/Equipment, Standards for Service Requirements & Standard document of TEC for Telecom Products and Services
- Formulation of Essential Requirements (ERs) under Mandatory Testing and Certification of Telecom Equipment (MTCTE)
- Field evaluation of Telecom Products and Systems
- Designation of Conformity Assessment Bodies (CABs)/Testing facilities
- Testing & Certification of Telecom products
- Adoption of Standards
- Support to DoT on technical/technology issues

For the purpose of testing, four Regional Telecom Engineering Centers (RTECs) have been established which are located in New Delhi, Bangalore, Mumbai, and Kolkata.

ABSTRACT

This Standard for Generic Requirements outlines the technical requirements of a Hybrid Set-Top Box (STB) with support for Ultra High Definition (UHD) and Virtual Reality (VR) capabilities. This standard outlines the important technical aspects such as UHD video rendering, immersive audio, low latency, advanced user interfaces, and virtual reality experience. These technical specifications aim to enhance the user experience, enabling viewers to enjoy UHD content while seamlessly transitioning into the immersive realms of VR and creating a new dimension in home entertainment.

CONTENTS

S. No.	Clause	Particulars	Page No.
	History Sheet		5
	References		6-7
Chapter 1			
1.1	Introduction		8
1.2	Description		8-11
1.3	Functional/operational requirements		12-15
1.4	Interface requirements		16
1.5	Quality requirements		16-17
1.6	EMI/EMC Requirements		17-20
1.7	Safety requirements		20
1.8	Security requirements		21
1.9	Other requirements (Maintenance)		21
	Abbreviations		22-23

HISTORY SHEET

<i>Sl. No.</i>	<i>Standard / document No.</i>	<i>Title</i>	<i>Remarks</i>
1.	Standard Number TEC 57060:2024	Hybrid Set-Top Box (STB) with support for Ultra High Definition (UHD) and Virtual Reality (VR).	New Standard For GR

REFERENCES

S. No.	Document No.	Title/Document Name
(I): TEC GR/IR/SDs		
1.	TEC/SD/DD/EMC - 221/05/OCT-16	Electromagnetic Compatibility Standard for Telecommunication Equipment
(II): ITU-T/ IEEE/ETSI/BIS/European Standard (To be updated)		
1.	BIS IS 15954 : 2012	Digital Set Top Box for MPEG-4 DTH Services
2.	BIS IS 16128 : 2013	Set Top Box For MPEG - 4 Digital Cable TV Services
3.	H.264/AVC	Advanced Video Coding
4.	H.265/HEVC	High Efficiency Video Coding
5.	EN 300 421	Digital Video Broadcasting (DVB); Framing structure, channel coding, and modulation for 11/12 GHz satellite services
6.	EN 300 429	Digital Video Broadcasting (DVB); Framing structure, channel coding, and modulation for cable systems
7.	ETSI TS 101 154	Digital Video Broadcasting (DVB); Specification for the use of Video and Audio Coding in Broadcast and Broadband Applications
8.	ISO/IEC 14496-10	Information Technology--Coding of audio-visual objects—Part 10: Advanced video coding
9.	ISO/IEC 11172-3	Information Technology - Coding of Moving Pictures and Associated Audio for Digital Storage Media at up to About 1,5 Mbit/s - Part 3: Audio
10.	IEEE 802.3	Ethernet Standard
11.	IEE 802.11	The set of standards that define communication for wireless LANs (wireless local area networks, or WLANs)
12.	ITU-T J.297	Requirements and functional specification of cable

		set-top box for 4K ultra high definition television
13.	ITU-T J.298	Requirements and technical specifications of a cable TV hybrid set-top box compatible with terrestrial and satellite TV transport
(III): Other Standards (To be updated)		
1.	CISPR 32(2015)/ EN 55032	Limits and methods of measurement of radio disturbance characteristics of ITE (Information Technology Equipment)
2.	IEC/EN 61000-4-2	Testing and measurement techniques – Electrostatic discharge immunity test
3.	IEC/EN 61000-4-3	Testing and measurement techniques – Radiated, Radio-frequency electromagnetic field immunity test
4.	IEC/EN 61000-4-4	Electromagnetic compatibility (EMC) - Part 4-4: Testing and measurement techniques –Electrical fast transient/burst immunity test
5.	IEC/EN 61000-4-5	Electromagnetic compatibility (EMC) - Part 4-5: Testing and measurement techniques – Surge immunity test
6.	IEC/EN 61000-4-6	Electromagnetic compatibility (EMC) - Part 4-6: Testing and measurement techniques – Immunity to conducted disturbances, induced by radio frequency fields
7.	IEC/EN 61000-4-11	Electromagnetic compatibility (EMC) Part 4- 11: Testing and measurement techniques Voltage dips, short interruptions, and voltage variations immunity tests
8.	IEC/EN 61000-4-29	Testing and measurement techniques – Voltage dips, short interruptions, and voltage variations on DC input power port immunity tests
9.	IS 13252 / IEC 60950	Information Technology Equipment -- Safety, Part 1: General Requirements

CHAPTER-1

1.1 Introduction

1.1.1 Hybrid Set-Top Box (STB) with support for Ultra High Definition (UHD) and Virtual Reality (VR) is a set-top box that supports UHD decoding and seamless integration of Virtual Reality (VR) capabilities. This STB supports Ultra High Definition (UHD) format and Virtual Reality (VR) services. These technologies have revolutionized the consumer experience of interacting with digital content. UHD and VR technologies have led to significant advancements in the entertainment and immersive content consumption industry. This Standard explores the technical requirements for set-top boxes that support UHD and virtual reality systems. This technical requirement will help consumers and industry in delivering superior audiovisual experiences and making UHD reception and Virtual Reality a reality in our lives.

1.1.2 As per the specification of ITU [ITU-R BT.2020], *Ultra-High Definition Television (UHDTV) provides viewers with an enhanced visual experience primarily by a wider field of view that covers a considerable part of the human natural visual field with appropriate screen sizes relevant to usage at home and in public places. Signal formats contributing to increasing compression efficiency are desirable for UHDTV systems as they have a larger number of pixels than HDTV systems.*

1.1.3 As per ITU specification of ITU [b-ITU-R BT.2420-0], *VR is a technology that replicates an environment, real or imagined, and simulates a user's physical presence and environment to allow for user interaction. Virtual reality artificially creates a sensory experience, which can include sight, touch, hearing, and smell. The current VR devices primarily present content to the visual and auditory systems. On occasion, haptics information is also included.*

1.2 Description

This section describes the block diagram and functional introduction of the

UHD-STB.

1.2.1 **UHD** - Ultra High Definition set-top boxes are electronic devices that are used to receive and decode UHD television signals. Through these boxes, users can access UHD content, which provides significantly better resolution and image quality than standard HD. UHD-STB may be available with various features such as internet connectivity, app support, and recording capabilities, enhancing the viewing experience. UHD-STB can have applications such as gaming in 4K, 8K or above resolution and play more applications, audio, videos, music, movies, etc. By using an Ethernet cable/Wi-Fi connection to connect to an internet server, user can surf the internet by using a web browser, etc.

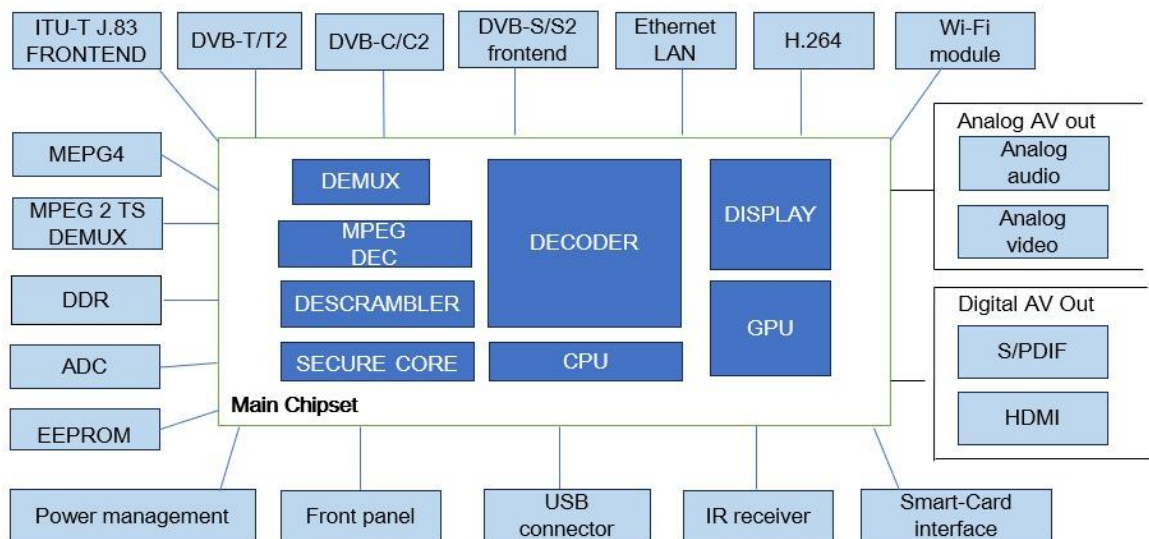

Fig 1: Block diagram of ultra-high definition (UHD) set-top box (ref: ITU-T J.298)

This architecture combines the high-performance UHD AVC decoding back-end and the internet connectivity through Ethernet/Wi-Fi.

The basic hardware diagram for the UHD STB is shown in Figure 1, which contains the following modules:

- I. The main chipset, the core module of the UHD STB, contains the central processing unit (CPU), graphics processing unit (GPU), audio and video decoder and all the relevant processors

- II. Memory, which contains double data rate (DDR) for software execution
- III. Frontend which includes at least one of ITU-T J.83, DVB-S/S2 and DVB C/C2
- IV. MPEG 2/MPEG4/H.264 /H.265 TS DEMUX for DVBS/S2 and DVBC/C2
- V. Power module
- VI. Ethernet interface
- VII. USB interface
- VIII. Wi-Fi 6 module
- IX. Audio and video output interface
- X. Conditional access system (CAS) / DRM
- XI. Keyboard interface
- XII. Bluetooth Interface for Headset Connectivity/ or game controller/ remote connectivity.
- XIII. For DVBS/DVBS2 services the STB will meet the standards as per BIS IS15954:2012 Digital Set Top Boxes for MPEG 4 DTH-Specification and for DVB C IS16128: 2013 Set TOP Boxes for MPEG 4 Digital Cable TV Services-Specification.

1.2.2 **VR** - The process of Virtual Reality (VR) involves immersing users in a computer-generated environment that imitates a three-dimensional space. The immersive feeling of being present in a digital environment is created by the combination of motion tracking, realistic graphics, and interactive controllers when a user puts on a VR headset. The display is constantly updated by the system as the user moves their head or interacts with the virtual world to maintain a seamless and immersive experience. The effectiveness of VR technology is attributed to the convergence of hardware and software elements.

VR is a virtual environment constructed by computers, where people can interact in real time using three-dimensional (3D) spatial information. Cloud VR services in these application scenarios are further classified as strong or weak interaction services.

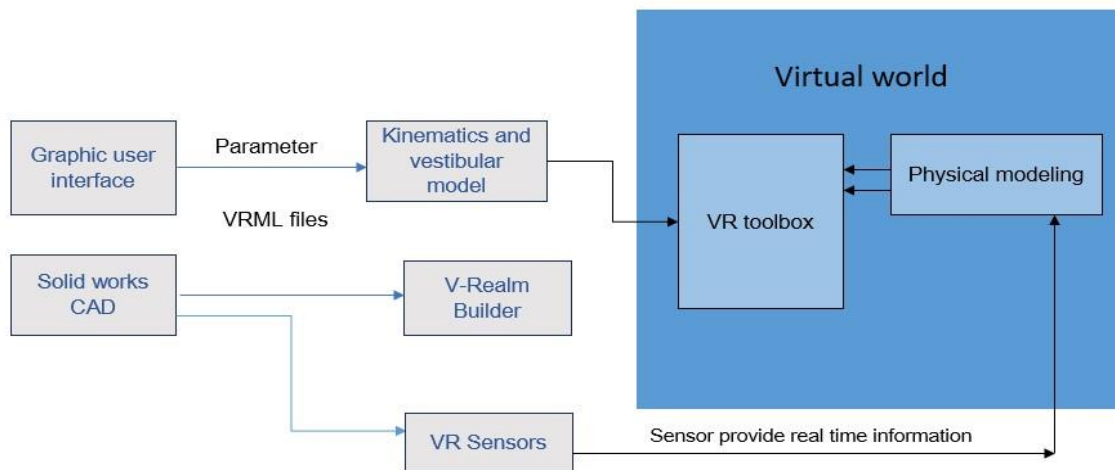

Fig 2: Block diagram of Virtual Reality Box

The basic hardware diagram for the VR is shown in Figure 2, which contains the following modules:

- I. Head-mounted display (HMD).
- II. The physical modeling module extends the capabilities of the virtual world and related software supports virtual reality graphics design.
- III. V realm builder is a feature of VR that allows you to design and customize your virtual reality world.
- IV. VR Sensors are embedded in the VR and provide real-time information and other data to the VR system.
- V. Wireless Module allows the VR system to connect to external devices, such as smartphones or tablets, enabling remote control, content sharing, and other features.
- VI. Graphical User Interface (GUI) in the VR box is the system of buttons, icons, and other graphical elements that allow users to interact with the interface.
- VII. The Main Processing Unit (CPU) is the brain of the system, responsible for executing commands.
- VIII. Controllers: Devices that user can hold in their hands to interact with the virtual world.

1.3 Functional/Operational Requirements

1.3.1 The STB shall support the reception and playback of AV programmes via cable/satellite/terrestrial/IP transport (can be max two services as in a hybrid STB (DVB S+IP or DVB C+IP + IP).

1.3.2 The STB shall support descrambling or decryption by integrating CAS and DRM solutions from qualified CAS and DRM solution providers and will meet the requirements as per the extant regulations.

1.3.3 The UHD set-top box shall serve as an enabling device between the streaming server and the user's display screen.

1.3.4 The STB shall be capable of running the SD/HD/UHD (4k, 8k, or above) video content after performing the following actions:

- Verifies the authenticity of the content to ensure its legitimacy and reliability.
- Decodes the video content, which is in a compressed format, to be displayable by the set-top box.
- Processes the audio content of the video in a similar manner.
- Scales the decoded video content to fit the screen size of the user's display screen, such as an HDTV or a monitor.
- Delivers the decoded and processed video and audio content to the user's display screen through a display output port, such as an HDMI port.

1.3.5 Decoders

The system shall support several common audio and video codecs.

1.3.5.1 Video Codecs

(i) The UHD STB shall be required to support the following video codecs:

(a) Up to 8k:-

S. No.	Resolutions	Video Codec	Supported Resolution	Codec Compression Ratio	Latency
--------	-------------	-------------	----------------------	-------------------------	---------

1	UHD 8k	H.265 8K	8K UHD(7680x4320)	2.5:1	6-10 ms
		H.265 8K	8K UHD (7680x4320)	3.0:1	3-6 ms
2	UHD 4k	H.265	4K UHD (3840x2160)	1.7:1	3-4 ms
3	FHD	H.264	1080p (1920x1080)	1.8:1	1-2 ms
4	FHD	H.262	720p (1280x720)	2.3:1	0.5-1 ms

(b) Up to 4k:-

S. No.	Resolutions	Video Codec	Supported Resolution	Codec Compression Ratio	Latency
1	UHD 4k	GGH.265	4K UHD (3840x2160)	1.7:1	3-4 ms
2	FHD	H.264	1080p (1920x1080)	1.8:1	1-2 ms
3	FHD	H.262	720p (1280x720)	2.3:1	0.5-1 ms

(ii) The system shall also support VP9 and AV1 codecs for lower latency and better video quality:

S. NO.	Video Codec	Resolutions	Supported Resolution	Codec Compression Ratio	Latency
1	VP9	UHD 8k	8KUHD (7680x4320)	2.0:1	2-5 ms
		UHD 4k	4KUHD (3840x2160)	1.5:1	1-3 ms
2	AV1	UHD 8k	8K UHD (7680x4320)	1.5:1	1-3 ms
		UHD 4k	4K UHD (3840x2160)	1.0:1	0.5-2 ms

- (iii) The following aspect ratios shall also be supported: 4:3 with center cut (cropped) 16:9, 4:3 with letterboxed 16:9, 16:9 with pillar boxed 4:3, 16:9 with zoomed 4:3 and Zoom.
- (iv) The STB shall at least simultaneous dual video decoding is recommended for a picture in picture (PIP) or fast channel change (FCC) application.
- (v) The STB shall support to switch between aspect ratios of 4:3 and 16:9 (and do suitable conversion in case of receiving an anamorphic video).

1.3.5.2 Audio Codecs:

STB should be capable to decompress/decode Audio compressed in accordance with:

- a) Capability to decompress and decode Audio using MPEG-1 Layer
- b) Capability to pass through the multichannel audio formats over compatible outputs such as HDMI, ARC, S/PDIF, etc.
- c) Capability to decompress and decode using other audio codecs may be provided as per the choice of the STB manufacturers as per the operators choices.

(i) The UHD STB shall support the following output mode for digital

Audio:-

- PCM (should be switched ON by default)
- RAW bit-stream
- Mono
- Dual mono

1.3.6 The STB shall support demodulation and decoding as per EN 300421/EN 300429/ETSI TS 101 154 of the RF input stream.

1.3.7 The STB shall be capable of supporting the individual channels by performing the required de-multiplexing of the MPTS stream to support individual channels by the end users.

1.3.8 The STB shall support output container formats such as flv, mkv, and mov etc.

1.3.9 The STB shall support video streaming protocols such as MPEG-DASH & HLS to allow mobile browser compatibility and for audio/video playback on end-user devices.

1.3.10 The STB shall support the hosting of live and static content through a web

server.

- 1.3.11 The STB shall support administrator authentication for the configuration of the STB.
- 1.3.12 The STB shall support Remote configuration and management. The STB shall also support configuration for the selection of frequency and streaming channels.
- 1.3.13 The STB shall support alert services as and when mandated and have the capability of targeted advertisements etc. through the service provider.
- 1.3.14 The STB shall allow the administrator to view viewership statistics.
- 1.3.15 The STB shall display the input and output streaming status and power ON/OFF status through LEDs.
- 1.3.16 The STB shall operate on power from 90V to 260V, 50Hz.
- 1.3.17 The STB should be able to operate in the environment of 5deg C to 50deg C.
- 1.3.18 The system shall support DVB-S/S2 (950MHz-2150MHz) and DVB-C/C2 (48 MHz - 650 MHz).
- 1.3.19 The STB shall provide overload protection.
- 1.3.20 The STB shall support a smooth OTA upgrade procedure so that the service downtime is kept to a minimum.
- 1.3.21 The STB shall require to support the CPU performance of the UHD STB by more than 2000DMIPS for execution of the application
- 1.3.22 The system shall require to support GPU with a 3D graphic accelerator supporting Open GL ES2.0 or above.
- 1.3.23 The STB shall have integrate front panel button, IR receiver, etc.
- 1.3.24 The STB shall support web browser and IP-related features.
- 1.3.25 The system shall require adequate flash memory.
- 1.3.26 The UHD STB shall support subtitles with the following specifications:
 - (i) [ITU-T J.83] Annex A (DVB-C) subtitle in accordance with [b-ETSI EN 300 743], including characters from code table ISO/IEC 8859-2
 - (ii) [ITU-T J.83] Annex C subtitle in accordance with [ARIB STD-B24].

1.4 Interface Requirements

- 1.4.1 The STB shall support RF Interface as per the DVB-S/S2/DVB- C/)/)/ ITU-T J.83 input stream using 75 ohms F type connectors.
- 1.4.2 The STB shall require to integrate an Ethernet network interface like the RJ 45 connector, IEEE 802.3 10/100Mbase-T, IPv6 (recommended).
- 1.4.3 The STB shall also support Ethernet/Wireless interface (IEEE 802.11) to Wi-Fi access points as per network topology.
- 1.4.4 The STB shall support a USB interface for programming and debugging of STB's.
- 1.4.5 The STB shall optionally integrate an S/PDIF interface (either an optical or coaxial connector) for digital audio output.
- 1.4.7 The STB shall support to integrate of an HDMI connector for digital video/audio output.
- 1.4.8 The STB shall support interconnection with the headset via wired/wireless mode.
- 1.4.9 The STB should be able to display the finger printing.

1.5 Quality Requirements

- 1.5.1 The manufacturer shall furnish the MTBF value. The minimum value of MTBF shall be 500,000 hours. The calculations shall be based on the guidelines given in either QA document No. QM-115 {January 1997} "Reliability Methods and Predictions" or any other international standards.
- 1.5.2 The equipment shall be manufactured in accordance with the international quality management system ISO 9001:2015 or any other equivalent ISO certificate for which the manufacturer should be duly accredited. A quality plan describing the quality assurance system followed by the manufacturer would be required to be submitted.
- 1.5.3 The equipment shall conform to the requirements for the Environment specified in TEC QA standards TEC 14016:2010 (earlier QM-333) "Standard for Environmental testing of Telecommunication Equipment's

or any other equivalent international standard, for operation, transportation, and storage. The applicable tests shall be for environmental category "D" including vibration and corrosion (salt mist).

1.6 EMI/EMC Requirements

The equipment shall conform to the EMC requirements as per the following standards and limits indicated therein. A test certificate and test report from an accredited test lab shall be furnished by a testing agency.

a) Conducted and radiated emissions (applicable to telecom equipment):

Name of EMC Standard: "CISPR 32 (2015) with amendments - Limits and methods of measurement of radio disturbance characteristics of Information Technology Equipment".

Limits:-

- i) To comply with Class B of CISPR 32 (2015) with amendments for indoor deployments and Class A of CISPR 32 (2015) with amendments for outdoor deployments.

b) Immunity to Electrostatic discharge:

Name of EMC Standard: IEC 61000-4-2 {2008} "Testing and measurement techniques of Electrostatic discharge immunity test".

Limits:-

- i) Contact discharge level 2 { ± 4 kV} or higher voltage;
- ii) Air discharge level 3 { ± 8 kV} or higher voltage;

c) Immunity to radiated RF:

Name of EMC Standard: IEC 61000-4-3 (2010) "Testing and measurement Techniques - Radiated RF Electromagnetic Field Immunity test".

Limits:-

For Telecom Equipment and Telecom Terminal Equipment without Voice interface (s)

Under Test level 2 {Test field strength of 3 V/m} for general purposes in the frequency range 80 MHz to 1000 MHz and protection against digital radio telephones and other RF devices in frequency ranges 800 MHz to 960 MHz and 1.4 GHz to 6.0 GHz.

d) Immunity to fast transients (burst):

Name of EMC Standard: IEC 61000-4-4 {2012} "Testing and measurement techniques of electrical fast transients/burst immunity test".

Limits:-

Test Level 2 i.e.

- a) 1 kV for AC/DC power lines;
- b) 0.5 kV for signal/control/data/telecom lines;

e) Immunity to surges:

Name of EMC Standard: IEC 61000-4-5 (2014) "Testing & Measurement techniques for Surge immunity test".

Limits:-

- i) For mains power input ports : (a) 2 kV peak open circuit voltage for the line to ground coupling (b) 1 kV peak open circuit voltage for the line-to-line coupling
- ii) For telecom ports : (a) 2kV peak open circuit voltage for the line to ground (b) 2KV peak open circuit voltage for the line-to-line coupling.

f) Immunity to conducted disturbance induced by Radio frequency fields:

Name of EMC Standard: IEC 61000-4-6 (2013) with amendments "Testing & measurement techniques-Immunity to conducted disturbances induced by radio frequency fields".

Limits:-

Under the test level 2 {3 V r.m.s.} in the frequency range 150 kHz-80 MHz for AC

/ DC lines and Signal /Control/telecom lines.

g) Immunity to voltage dips & short interruptions (applicable to only AC mains power input ports, if any):

Name of EMC Standard: IEC 61000-4-11 (2004) “Testing & measurement techniques- voltage dips, short interruptions and voltage variations immunity tests”.

Limits:-

- i) a voltage dip corresponding to a reduction of the supply voltage of 30% for 500ms (i.e. 70 % supply voltage for 500 ms)
- ii) a voltage dip corresponding to a reduction of the supply voltage of 60% for 200ms; (i.e. 40% supply voltage for 200ms) and
- iii) a voltage interruption corresponding to a reduction of the supply voltage of > 95% for 5s.
- iv) a voltage interruption corresponding to a reduction of the supply voltage of >95% for 10s.

h) Immunity to voltage dips & short interruptions (applicable to only DC power input ports, if any):

Name of EMC Standard: IEC 61000-4-29:2000: Electromagnetic compatibility (EMC) - Part 4-29: Testing and measurement techniques - Voltage dips, short interruptions, and voltage variations on DC input power port immunity tests.

Limits:-

- i. Voltage Interruption with 0% of supply for 10ms. Applicable Performance Criteria shall be B.
- ii. Voltage Interruption with 0% of supply for 30ms, 100ms, 300ms and 1000ms. Applicable Performance Criteria shall be C.
- iii. Voltage dip corresponding to 40% & 70% of supply for 10ms, 30 ms. Applicable Performance Criteria shall be B.
- iv. Voltage dip corresponding to 40% & 70% of supply for 100ms, 300 ms and 1000ms. Applicable Performance Criteria shall be C.

- v. Voltage variations correspond to 80% and 120% of supply for 100 ms to 10s as per Table 1c of IEC 61000-4-29. Applicable Performance Criteria shall be B.

Note: - For checking compliance with the above EMC requirements, the method of measurement shall be in accordance with TEC Standard No. TEC/SD/DD/EMC-221/05/OCT-16 and the referenced base standards i.e. IEC and CISPR standards and the references mentioned therein unless otherwise specified specifically. Alternatively, corresponding relevant Euro Norms of the above IEC/CISPR standards are also acceptable subject to the condition that frequency range and test level are met as per above mentioned sub clauses (a) to (h) and TEC Standard TEC/SD/DD/EMC-221/05/OCT-16.

The details of IEC/CISPR and their corresponding Euro Norms are as follows:

IEC/CISPR	Euro Norm
CISPR 11	EN 55011
CISPR 32	EN55032
IEC 61000-4-2	EN 61000-4-2
IEC 61000-4-3	EN 61000-4-3
IEC 61000-4-4	EN 61000-4-4
IEC 61000-4-5	EN 61000-4-5
IEC 61000-4-6	EN 61000-4-6
IEC 61000-4-11	EN 61000-4-11
IEC 61000-4-29	EN 61000-4-29

1.7 Safety Requirements

1.7.1 The equipment shall conform to:

- i. IS 13252 part 1: 2010 “Information Technology Equipment –Safety- Part 1: General Requirements” [equivalent to IEC 60950-1 {2005} “Information Technology Equipment –Safety- Part 1: General Requirements”

IEC 62368-1: 2018 “Audio/video, information and communication technology equipment - Part 1: Safety requirements”

1.8 Security Requirements

The UHD STB shall comply with the security requirements of the CAS provider and at least the following features shall be supported:

- i. Embedded advanced security CAS which will be defined by CAS providers and operators
- ii. Embedded DRM client system for OTT/IPTV streaming which will be defined by the operator.
- iii. Contain a secure bootloader that shall be stored in write protected flash area, secure boot process with signature verification shall be applied during boot up process, only the signed software can be executed
- iv. Support high-definition content protection (HDCP) copy protection on HDMI output

1.9 Others requirements (Maintenance)

The STB shall support following maintenance requirements for the software run in a UHD set-top box:

1.9.1 Software upgrade

The STB shall be required to provide a software download mechanism for upgrading software modules.

1.9.2 The STB shall require to support one of the following upgrade methods:

- OTA

1.9.3 Security Updates

The STB provider shall ensure security updates apply promptly to protect the set-top box from vulnerabilities and security threats. This includes updating the operating system, apps, and any built-in security features.

1.9.4 App Maintenance

The STB shall support third-party apps, regular updates and workability with these apps. The system shall update to the latest versions available through the app store or platform to ensure to functions properly and remains secure.

ABBREVIATIONS

For the purpose of this document the following abbreviations apply:

AVC	Digital Audio Codec
CAS	Conditional Access System
CISPR	International Special Committee on Radio Interference
CPU	Central Processing Unit
DDR	Dial on Demand Routing
DEMUX	De-multiplexer
DRM	Digital Rights Management
DTH	Direct to Home
DTT	Digital Terrestrial Television
DVB-S/S2	Digital Video Broadcasting – Satellite/ Satellite Second
DVB-T/T2	Digital Video Broadcasting – Second Generation Terrestrial
EMC	Electromagnetic Compatibility
EMI	Electromagnetic interference
GUI	Graphical User Interface
HDCP	High Definition Content Protection
HDMI	High Definition Multimedia Interface
HEVC	High Efficiency Video Coding
HLS	HTTP Live Streaming
IEEE	Institute of Electrical and Electronics Engineers
LAN	Local area network
MPEG-1	Moving Picture Experts Group Phase 1
MTBF	Mean Time Between Failures
OTT	Over-the-top
S/PDIF	Sony/Philips Digital Interface Format
STB	Set Top Box
UHD	Ultra High Definition
UI	User Interface
USB	Universal Serial Bus

VR	Virtual Reality
Wi-Fi	Wireless Fidelity
WLAN	Wireless local area network
IPTV	Internet Protocol Television

=====**End of the document**=====