



वर्गीय आवश्यकताओं के लिए मानक

टीईसी २११३०: २०२५

STANDARD FOR GENERIC REQUIREMENTS

TEC 21130: 2025

5जी डुअल कोर

5G Dual Core



दूरसंचार अभियांत्रिकी केंद्र

खुर्शीदलाल भवन, जनपथ, नई दिल्ली-110001, भारत

TELECOMMUNICATION ENGINEERING CENTRE

KHURSHID LAL BHAWAN, JANPATH, NEW DELHI-110001, INDIA

www.tec.gov.in

© टीईसी, २०२५
© TEC, 2025

इस सर्वाधिकार सुरक्षित प्रकाशन का कोई भी हिस्सा, दूरसंचार अभियांत्रिकी केंद्र, नई दिल्ली की लिखित स्वीकृति के बिना, किसी भी रूप में या किसी भी प्रकार से जैसे -इलेक्ट्रॉनिक, मैकेनिकल, फोटोकॉपी, रिकॉर्डिंग, स्कैनिंग आदि रूप में प्रेषित, संग्रहीत या पुनरुत्पादित न किया जाए।

All rights reserved and no part of this publication may be reproduced, stored in a retrieval system or transmitted, in any form and by any means - electronic, mechanical, photocopying, recording, scanning or otherwise, without written permission from the Telecommunication Engineering Centre, New Delhi.

Release 1: December, 2025

FOREWORD

Telecommunication Engineering Centre (TEC) is the technical arm of Department of Telecommunications (DOT), Government of India. Its activities include:

- Framing of TEC Standards for Generic Requirements for a Product/Equipment, Standards for Interface Requirements for a Product/Equipment, Standards for Service Requirements & Standard document of TEC for Telecom Products and Services
- Formulation of Essential Requirements (ERs) under Mandatory Testing and Certification of Telecom Equipment (MTCTE)
- Field evaluation of products and Systems
- Designation of Conformity Assessment Bodies (CABs)/Testing facilities
- Testing & Certification of Telecom products
- Adoption of Standards
- Support to DoT on technical/technology issues

For the purpose of testing, four Regional Telecom Engineering Centers (RTECs) have been established which are located at New Delhi, Bangalore, Mumbai, and Kolkata.

ABSTRACT

This standard for Generic Requirements (GR) for 5G Dual Core outlines the key functional, general and other technical requirements for the implementation of 5G Dual Core system in Indian telecom networks. This document defines the key network functions, interfaces supporting interworking, QoS assurance, mobility management and legacy LTE system support. This standard aligns with international standards (i.e., 3GPP), while addressing specific needs of Indian telecom networks.

CONVENTIONS

In this document, requirements are classified as follows:

- The keywords "shall" or "is/are required to" indicate a requirement or requirements, which must be mandatorily complied and from which no deviation is permitted, if conformance to this document is to be claimed; and
- The keyword "should" indicate a recommended requirement, which is not mandatory for claiming conformance to this document. However, its implementation is strongly advised as it represents best practices or preferred functionality; and
- The keywords "optional" or "may" indicate an optional requirement, which is permissible for exclusion from mandatory compliance, unless the said requirement is claimed to be complied by the vendor. These terms are not intended to imply that the vendor's implementation must provide the option; it means the vendor may optionally provide the feature and still claim conformance with this document.

CONTENTS

<i>Clause No.</i>	<i>Particulars</i>	<i>Page No.</i>
History Sheet		7
References		8
CHAPTER 1		
1	Introduction	11
1.1	Overview	11
1.2	Architecture	12
CHAPTER 2		
2	Functional Requirements	19
2.1	General Requirements	19
2.2	Converged Nodes Requirements	21
2.3	Other Functional Requirements	24
CHAPTER 3		
3	OMC / EMS Requirements	25
3.1	Management Functions	25
3.2	OMC Database	25
3.3	OMC Generic Features	26
CHAPTER 4		
4	General Requirements	27
CHAPTER 5		
5	Other Requirements	29
5.1	Software Requirements	29
5.2	Software Maintenance Requirements	29
5.3	Documentation	29
5.4	Quality Requirements	30
5.5	Safety Requirements	30

5.6	Security Requirements	30
5.7	EMI / EMC Requirements	31
CHAPTER 6		
6	Information for the Procurer of Product	35
Abbreviations		37

HISTORY SHEET

<i>Sl.No.</i>	<i>Standard No.</i>	<i>Title</i>	<i>Remarks</i>
1.	TEC 21130:2025	5G Dual Core	New Standard

REFERENCES

<i>S. No.</i>	<i>Document No.</i>	<i>Title/ Document Name</i>
1.	3GPP TS 23.501	5G; System architecture for the 5G System (5GS)
2.	3GPP TS 23.502	5G; Procedures for the 5G System (5GS)
3.	3GPP TS 33.501	5G; Security architecture and procedures for 5G System
4.	3GPP TS 29.502	5G; 5G System; Session Management Services; Stage 3
5.	3GPP TS 32.255	5G; Telecommunication management; Charging management; 5G data connectivity domain charging; Stage 2
6.	3GPP TS 23.503	5G; Policy and charging control framework for the 5G System (5GS); Stage 2
7.	3GPP TS 29.244	LTE; 5G; Interface between the Control Plane and the User Plane nodes
8.	3GPP TS 23.632	LTE; 5G; User data interworking, coexistence and migration; Stage 2
9.	3GPP TS 29.510	5G; 5G System; Network function repository services; Stage 3
10.	3GPP TS 29.513	5G; 5G System; Policy and Charging Control signalling flows and QoS parameter mapping; Stage 3

11.	3GPP TS 29.521	5G; 5G System; Binding Support Management Service; Stage 3
12.	3GPP TS 32.290	5G; Telecommunication management; Charging management; 5G system; Services, operations and procedures of charging using Service Based Interface (SBI)
13.	3GPP TS 29.504	5G; 5G System; Unified Data Repository Services; Stage 3
14.	3GPP TS 29.520	5G; 5G System; Network Data Analytics Services; Stage 3
15.	3GPP TS 32.240	LTE; Telecommunication management; Charging management; Charging architecture and principles
16.	3GPP TS 22.278	Service requirements for the Evolved Packet System (EPS)
17.	3GPP TS 36.411	Evolved Universal Terrestrial Radio Access Network (E-UTRAN); S1 layer 1
18.	3GPP TS 36.413	Evolved Universal Terrestrial Radio Access Network (E-UTRAN); S1 Application Protocol (S1AP)
19.	3GPP TS 22.115	Service aspects; Charging and billing
20.	3GPP TS 23.203	Policy and Charging Control Architecture
21.	3GPP TS 33.106	Lawful Interception Requirements

22.	3GPP TS 33.401	3GPP System Architecture Evolution (SAE); Security Architecture
23.	3GPP TS 23.502	Procedures for the 5G System (5GS)
24.	ETSI GS NFV 002	Network Functions Virtualization (NFV); Architectural Framework
25.	ETSI GS MEC 003	Multi-Access Edge Computing (MEC); Framework and Reference Architecture

CHAPTER 1

1 Introduction

1.1 Overview

The 5G Dual Core system provides a unified platform that seamlessly converges the Evolved Packet Core (EPC) and the 5G Core (5GC), ensuring interoperability across these network generations. The system enables smooth interworking between Long Term Evolution (LTE) and 5G networks via standardized interfaces, such as N26, facilitating efficient EPC–5GC convergence. This system supports both Non-Standalone (NSA) and Standalone (SA) 5G deployment modes, offering flexibility to accommodate diverse network scenarios. With a modular and scalable design, the platform supports network expansion and manages varying traffic demands effectively.

This Generic Requirement (GR) document specifies the key functional, general and other technical requirements for the deployment of 5G Dual Core systems in India, with an emphasis on ensuring service continuity and harmonization with global standards and best practices. It sets out standardized requirements in line with international specifications (i.e., 3GPP), while also addressing the specific needs of Indian telecom networks.

1.2 Architecture

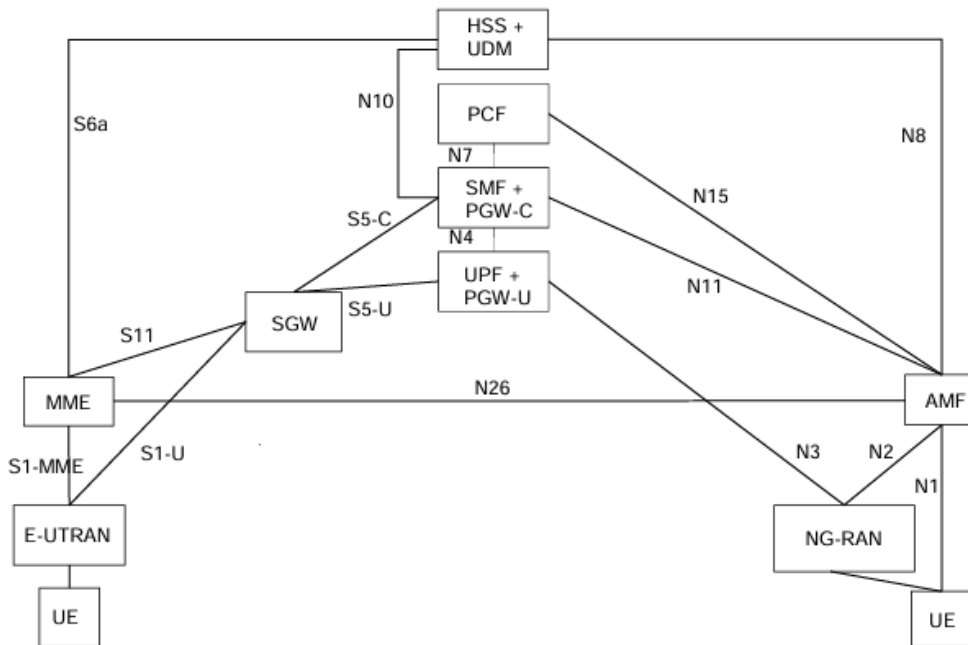

Figure 1: Architecture for interworking between 5GS and EPC/E-UTRAN¹

The Figure 1 above, illustrates the interworking between the EPC and the 5GC network elements, highlighting the 5G Dual-Core architecture.

1.2.1 Network Elements

The network elements involved in the interworking of 5GC and EPC for providing 5G Dual Core services are given below:

1.2.1.1 Converged Control Plane function: The 5G SMF (Session Management Function) and LTE PGW-C (Packet Data Network Gateway Control Plane) shall be converged. This convergence is essential for maintaining session continuity when a UE moves between LTE and 5G, ensuring uninterrupted service by retaining the user's IP address and other session parameters during handover. Optionally, the LTE SGW-C (Serving Gateway Control Plane) may also be combined in the converged control plane function.

1.2.1.2 Converged Mobility function: The LTE MME (Mobility Management Function) and the 5G AMF (Access and Mobility Management Function) shall

¹ 3GPP TS 23.501 - System architecture for the 5G System

support the N26 interface for interworking. The N26 interface enable seamless mobility and session continuity for UE during inter-system handovers between LTE and 5G networks. It allows the network to maintain a single valid Mobility Management (MM) state for the UE, either in the AMF or the MME, during the handovers. Optionally, the LTE MME and 5G AMF may be converged into a single mobility function.

1.2.1.3 Converged User Plane Function: The LTE PGW-U (Packet Data Network Gateway User Plane) and 5G UPF (User Plane Function) shall be converged. This convergence allows efficient resource utilization and smooth interoperability between the two technologies, ensuring seamless user experience during handover from EPC to 5GC and vice-versa. Optionally, the LTE SGW-U (Serving Gateway User Plane) may also be combined in the converged user plane function.

1.2.1.4 Converged Subscriber Database: The Home Subscriber Server (HSS) and Unified Data Management (UDM) functionalities may be converged into a unified node, referred to as UDM+HSS.

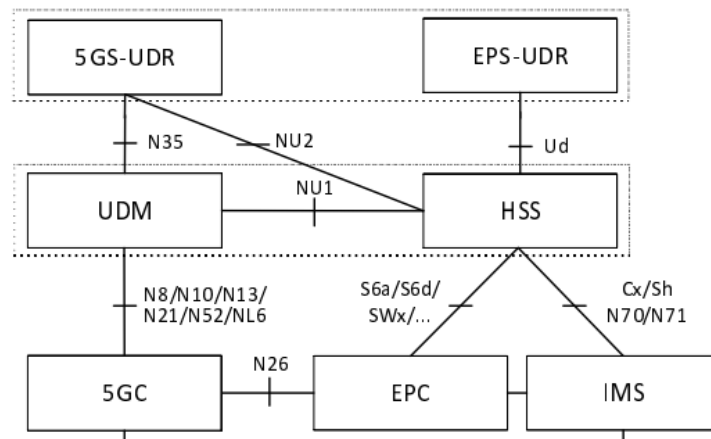

Figure 2 - Architecture for Direct UDM-HSS interworking in reference point representation²

² 3GPP TS 23.632: User data interworking, coexistence and migration; Stage 2

This convergence may be achieved through one of the following approaches:

- A. **Interface-Based Convergence:** The LTE-HSS and 5G-UDM communicate via the Nu1 interface, maintaining separate functional entities while enabling interoperability.

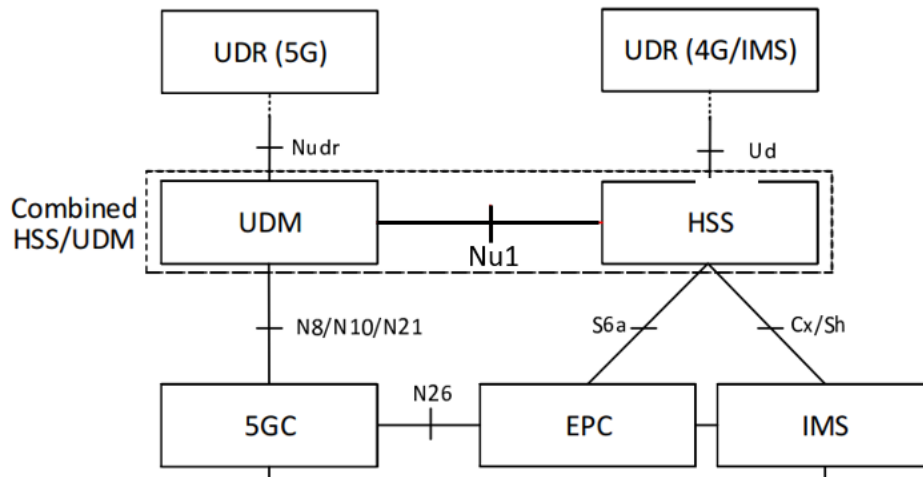

Figure 3: Architecture for Direct UDM-HSS Interworking with independent UDRs

- B. **Database-Centric Convergence:** A common database supporting both LTE-HSS and 5G-UDM functions is implemented to enable 5G Dual Core functions, allowing seamless access and management of subscriber data across these technologies.

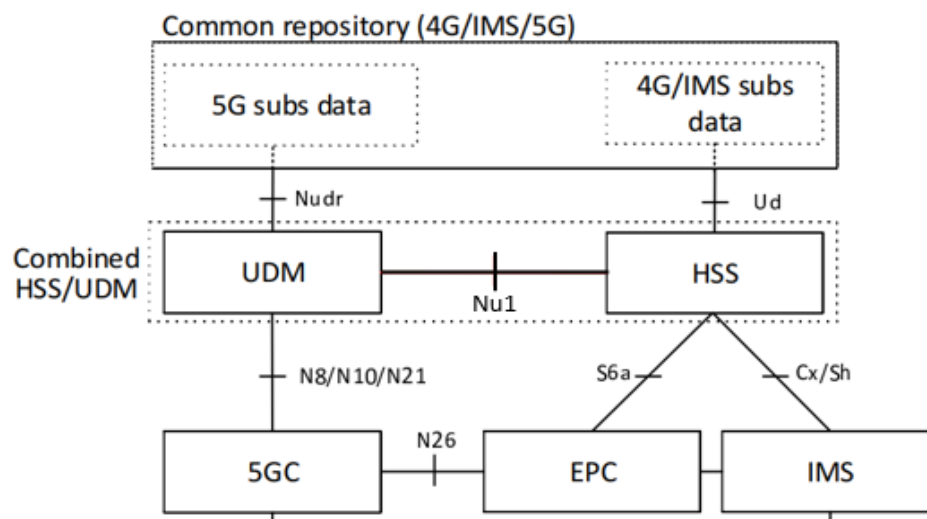

Figure 4: Architecture for Direct UDM-HSS Interworking with a common repository

Note: The *NU1*, *Nudr* and *Ud* interfaces may be optional for converged Subscriber Database (*HSS+UDM*) based on the solution offered by vendor.

1.2.1.5 **Converged Policy Function:**

The LTE PCRF and 5G PCF may be converged, enabling unified policy control and QoS management across both LTE and 5G networks, thereby ensuring consistent policy enforcement and service quality for all subscribed services.

1.2.1.6 **E-UTRAN (Evolved Universal Terrestrial Radio Access Network):** The LTE radio access network responsible for connecting the UE to the EPC

1.2.1.7 **NG-RAN (Next Generation Radio Access Network):** The 5G radio access network connecting the UE to the 5G Core.

1.2.2 **Interfaces and Reference Points**

This section describes the interfaces of this architecture.

- a. **N1-** Interface between the User Equipment (UE) and the Access and Mobility Management Function (AMF) in the 5G core. It is used for signalling and mobility management.
- b. **N2-** Interface between the Next-Generation Radio Access Network (NG-RAN) and the AMF in the 5G core. It handles control-plane signalling for mobility and session management.
- c. **N3-** Interface between the NG-RAN and the User Plane Function (UPF) in the 5G core. It transports user-plane traffic.
- d. **N4-** Interface between the Session Management Function (SMF) and the UPF in the 5G core. It is used for session and user-plane resource management.
- e. **N7-** Interface between the SMF and the Policy Control Function (PCF). It is used for exchanging policy-related information to enforce Quality of Service (QoS).
- f. **N8-** Interface between UDM and AMF for subscriber data.

- g. **N10**- Interface between the UDM and the SMF in the 5G core. It is used to retrieve subscriber information and authentication data.
- h. **N11**-Interface between the AMF and the SMF. It facilitates session management and mobility signalling.
- i. **N15**- Interface between the AMF and PCF.
- j. **S5-C**- Interface between the SGW-C (control plane of SGW) and the Packet Data Network Gateway Control (PGW-C) in LTE. It handles control-plane signalling for bearer management.
- k. **S5-U**- Interface between the SGW-U and the Packet Gateway User Plane (PGW-U). It carries user-plane data in LTE.
- l. **S6-a**- Interface between the MME and the HSS in LTE. It provides authentication, authorization, and subscriber profile information.
- m. **S11**- Interface between the MME and the SGW in LTE. It is used for control-plane signalling.
- n. **S1-U**- Interface between the E-UTRAN and the Serving Gateway (SGW) in LTE. It is used for user-plane traffic.
- o. **S1-MME**- Interface between the Evolved Universal Terrestrial Radio Access Network (E-UTRAN) and the Mobility Management Entity (MME) in LTE. It carries signalling for control-plane operations.
- p. **N26**- Interface between the MME in LTE and the AMF in the 5G core. It enables interworking between LTE and 5G systems for mobility management and session continuity.
- q. **NU1**: Reference point between the HSS in LTE and the UDM in 5GC.
- r. **NU2**: Reference point between the HSS in LTE and the 5GS-UDR
- s. **Ud**: Interface between HSS and LTE UDR.
- t. **N12**: Interface between AMF and Authentication Server Function (AUSF) for authentication procedures in the 5G core, especially during UE registration.
- u. **N13**: Interface between AUSF and UDM supports authentication credential retrieval and verification.

- v. **N14:** Interface between AMF nodes facilitates AMF-to-AMF communication for UE mobility and context transfer.
- w. **N35:** Interface between UDM and UDR for accessing subscription and user-related data stored in the UDR.
- x. **N36:** Interface between PCF and UDR for accessing policy-related data stored in the UDR.
- y. **N28:** Interface between PCF and Charging Function (CHF) supports charging policy enforcement and reporting.
- z. **N40:** Interface between SMF and CHF for session-related charging data exchange.
- aa. **NL6:** Interface between Gateway Mobile Location Centre (GMLC) and UDM to enable the GMLC to access subscriber session information from UDM
- bb. **Gx:** Interface between PGW-C and Policy and Charging Rules Function (PCRF) in LTE for policy control in the LTE EPC.
- cc. **Gy:** Interface between PGW and Online Charging System (OCS) handles real-time charging in LTE.

1.2.3 Service-based interfaces

The 5G System Architecture contains the following service-based interfaces:

- a. **Namf:** Service-based interface exhibited by AMF.
- b. **Nsmf:** Service-based interface exhibited by SMF.
- c. **Nnef:** Service-based interface exhibited by NEF.
- d. **Npcf:** Service-based interface exhibited by PCF.
- e. **Nudm:** Service-based interface exhibited by UDM.
- f. **Naf:** Service-based interface exhibited by AF.
- g. **Nnrf:** Service-based interface exhibited by NRF.
- h. **Nnssaaf:** Service-based interface exhibited by NSSAAF.
- i. **Nnssf:** Service-based interface exhibited by NSSF.
- j. **Nausf:** Service-based interface exhibited by AUSF.
- k. **Nudr:** Service-based interface exhibited by UDR.
- l. **Nudsf:** Service-based interface exhibited by UDSF.
- m. **N5g-eir:** Service-based interface exhibited by 5G-EIR.
- n. **Nnwdaf:** Service-based interface exhibited by NWDAF.
- o. **NCHF:** Service-based interface exhibited by CHF.
- p. **Nucmf:** Service-based interface exhibited by UCMF.
- q. **Nhss:** Service-based interface exhibited by HSS.

CHAPTER 2

2 Functional Requirements

2.1 General Requirements

2.1.1 In order to allow Inter-RAT (IRAT) handover between LTE and 5G networks and to enable service and session continuity and mobility outside of the technology coverage, at least the following nodes shall be converged:

2.1.1.1 SMF & PGW-C

2.1.1.2 UPF & PGW-U

2.1.1.3 Between MME and AMF, N26 interface shall be established

2.1.2 In addition, the following nodes may be converged together to achieve interworking between EPC and 5GC:

2.1.2.1 UDM & HSS

2.1.2.2 PCF & PCRF

2.1.3 UEs that are subject to 5GC and EPC interworking shall be served by converged nodes.

2.1.4 The 5G Dual Core shall support:

2.1.4.1 Single registration for UE for interworking between EPC and 5GC via N26 interface.

2.1.4.2 Interoperability with legacy LTE network elements, including support for S1 interface, to maintain backward compatibility during phased migration.

2.1.4.3 Dynamic session anchoring and relocation between UPF and PGW-U based on UE mobility and service continuity requirements.

- 2.1.4.4 VoLTE and VoNR interworking, ensuring seamless voice continuity during handovers between LTE and 5G networks.
- 2.1.4.5 Lawful interception and regulatory compliance across both RATs, ensuring that all security obligations are met in a converged environment.
- 2.1.4.6 Fallback mechanisms to EPC in case of 5GC unavailability, ensuring uninterrupted service delivery.
- 2.1.4.7 Inter-PLMN mobility and roaming scenarios, including seamless transitions between home and visited networks across LTE and 5G.
- 2.1.5 The converged nodes shall be designed to support network slicing, allowing differentiated services and resource allocation for 5G services.
- 2.1.6 The 5G Dual-Core architecture shall include redundancy and high availability mechanisms across converged nodes to ensure carrier-grade reliability and fault tolerance.
- 2.1.7 The 5G Dual-Core architecture shall enable centralized analytics and monitoring for both EPC and 5GC domains, allowing real-time visibility into session performance, mobility events, and resource utilization.
- 2.1.8 The 5G Dual Core may:
 - 2.1.8.1 Enable common subscriber data management across 5G and LTE networks through a unified UDM+HSS and PCF+PCRF architecture, ensuring consistent policy enforcement and seamless mobility.
 - 2.1.8.2 Support common charging functions, integrating CHF (Charging Function) and OCS/OFCS to provide unified charging records and real-time credit control across RATs.
 - 2.1.8.3 Support integration with standards-based MEC platforms (as per ETSI GS MEC 003), enabling local breakout and low-latency service delivery for both LTE and 5G UEs, with appropriate traffic steering and session management
 - 2.1.8.4 Support containerized and cloud-native architectures, supporting orchestration (e.g., Kubernetes), and resource optimization in cloud environments. Compliance to ETSI GS NFV reference architecture is preferable.

2.2 Converged Nodes Requirements

2.2.1 SMF + PGW-C

2.2.1.1 PGW-C and SMF shall be converged into a single node SMF+PGW-C.

Optionally, SGW-C may also be integrated into the same node, resulting in a unified control function as SMF+PGW-C+SGW-C.

2.2.1.2 This converged node shall:

2.2.1.2.1 Enable IP address preservation and session continuity during mobility between LTE and 5G networks.

2.2.1.2.2 Support of S5-C interface towards LTE SGW in case of monolithic SGW (not required for SMF+PGW-C+SGW-C) and N11 towards 5G AMF.

2.2.1.2.3 Support N7 interface towards converged PCF.

2.2.1.3 If the converged node is selected for a PDN connection, the policy interactions that normally occur between the PGW and the PCRF shall be replaced by the corresponding interactions between the converged node and the PCRF or converged PCF+PCRF node.

2.2.1.4 If both PGW-C and the converged node are available, then MME shall select the converged node when UE's subscription from HSS indicates support for interworking with 5GS for the APN.

2.2.1.5 In order to support the interworking with EPC, the converged node shall provide information over N4 to the UPF+PGW-U related to the handling of traffic over S5-U or S1-U in case of converged UPF+SGW-U+PGW-U node.

2.2.2 UPF + PGW-U

2.2.2.1 UPF and PGW-U shall be converged into a single node UPF+PGW-U. Optionally, SGW-U may also be integrated with the UPF, resulting in a unified user plane node functioning as UPF+PGW-U+SGW-U.

2.2.2.2 The converged node shall support S5-U interface towards LTE SGW (in case of monolithic SGW) and N3 towards NG-RAN.

2.2.2.3 The converged node shall support the N4 interface for receiving control information from the SMF+PGW-C.

2.2.2.4 If there is another UPF between the NG-RAN and the converged node, then, the converged node shall support N9 towards the additional UPF, if needed.

2.2.2.5 The convergence of UPF and PGW-U shall enable session anchoring and maintain continuity during mobility between LTE and 5G networks.

2.2.2.6 In the case of Cellular IoT 5GS optimization, the converged node may store the current Small Data Rate Control Status for all active PDU Sessions when the UE moves to the EPC, and shall restore the status when the UE returns to the 5GC.

2.2.3 UDM + HSS

HSS and UDM may be converged into a single node and shall support the following functions:

2.2.3.1 The converged node shall support the subscriber data for both LTE and 5G subscriptions in a unified manner. This includes permanent subscriber data, which can only be changed administratively and temporary subscriber data may change due to normal system operation.

2.2.3.2 The converged node shall have S6a reference point to provide services towards the MME and N8 reference point to provide services towards the AMF. The converged node shall provide the following 3GPP reference points:

N8, N10, N13 and NL6 corresponding to the 3GPP UDM network function (including ARPF). N35 and NU1 may be optional reference points based on the converged database (UDM+HSS) solution offered by vendor.

2.2.3.3 For interworking with the EPC, the SUPI allocated to the 3GPP UE shall always be based on an IMSI to enable the UE to present an IMSI to the EPC.

2.2.3.4 The subscription identifier shall be an IMSI for EPC based interactions. The UDM shall extract the IMSI from the user's SUPI for interactions with the HSS.

2.2.3.5 The converged node may support CN Type Change Event subscription with an optional Duration of Reporting parameter. Upon expiry of the specified duration, the HSS+UDM shall locally unsubscribe the CN Type Change Event without requiring explicit signaling interaction from the subscribing network function.

2.2.3.6 Either the converged node shall continue to support all required interfaces with the respective nodes of both EPC and 5GC or for interface-based convergence the Dual Core system shall support an interface between the HSS and the UDM.

2.2.4 **PCF + PCRF**

PCF and PCRF may be converged into a single node and shall support following functions:

2.2.4.1 Policy related data for LTE and 5G subscribers shall be unified and shall be accessible to the converged node.

2.2.4.2 This converged node shall support hybrid access wherein N7 can support Gx traffic based on the availability of SMF+PGW-C for LTE & 5G services.

2.2.4.3 It shall have N15 interface towards AMF.

2.2.4.4 It shall have N28 interface towards CHF.

2.2.5 **AMF & MME convergence through N26 interface**

2.2.5.1 AMF and MME shall be converged through N26 interface.

2.2.5.2 The convergence of these nodes shall enable seamless mobility management and signalling continuity between EPC and 5G Core networks.

2.2.5.3 This convergence shall support the S1-MME interface towards eNodeB (LTE) and the N2 interface towards gNodeB (5G).

2.2.5.4 This convergence shall support the N11 interface towards SMF and the S11 interface towards SGW-C for session management.

2.2.5.5 This convergence shall enable unified handling of UE registration, authentication, and mobility procedures across both LTE and 5G access networks.

2.2.5.6 This convergence shall support interaction with UDM and HSS for unified subscriber data access and authentication.

2.3 Other Functional Requirements

2.3.1 All the other functional requirements for EPC nodes and for 5G Network Functions in addition to the above requirements shall be as per Standard for Generic Requirements for Evolved Packet Core (EPC) (TEC 22150:2019) and Standard for Generic Requirements for 5G Core (TEC 22160:2023).

CHAPTER 3

3 OMC/ EMS Requirements

The OMC allows centralized operation of the various units in the system and functions needed to maintain the sub-systems. The OMC provides the dynamic monitoring and controlling of the network management functions.

3.1 Management Functions

The following management functions shall be carried out through the corresponding OMCs:

- 3.1.1. Configuration management
- 3.1.2. Fault report and alarm handling
- 3.1.3. Performance supervision/management
- 3.1.4. Storage of system software and data
- 3.1.5. Security management

3.2 OMC database

- 3.2.1. The OMC shall use the relational/object-oriented database to store and hold the necessary information for the parameters used in the OMC.
- 3.2.2. The OMC database shall include configuration data, maintenance data, fault data and performance / QoS data. It shall also include the alarms and notifications instances of the NEs to be consumed by various services in OMC.
- 3.2.3. The database in the OMC shall reside in a disk with mirroring capability.
- 3.2.4. The OMC shall be capable of storage of the generated performance data. The methods and capacity of storage provided with the system shall be stated.
- 3.2.5. OMC shall supports upto 3 days of storage for PM (Performance Management) Data.

- 3.2.6. Provision shall be available for collection of statistical information relating to events in the network. Collection frequency shall be configurable.
- 3.2.7. The OMC database shall contain the fault history of the whole network under its command. As a minimum, it shall be possible to search and display data according to the following criteria:
 - (i) Network elements
 - (ii) Severity class
 - (iii) Event type.

3.3 OMC Generic Features

- 3.3.1. OMC software – UNIX/LINUX/Windows System Platform
- 3.3.2. It shall optionally support interface like CORBA / TCP / IP / CMIP / SNMP/ REST / HTTP etc., to enable it to work with a remote NMS
- 3.3.3. Support Ethernet connectivity with remote network elements.
- 3.3.4. Graphical User Interface (GUI).
- 3.3.5. Management through Element Management System
- 3.3.6. On-Line Help.
- 3.3.7. Consistency Checks (Optional).
- 3.3.8. Configuration Change/Event Log.
- 3.3.9. Object Alarm Status Management / Display.
- 3.3.10. Collection of PM counters.
- 3.3.11. Limited Access Restriction by User.
- 3.3.12. Access Restriction by Function and by Operation.

CHAPTER 4

4 General Requirements

- 4.1 The network elements (NEs) shall support:
 - 4.1.1 Command Line Interface (CLI)/ RESTful / NETCONF / SNMP for configuring.
 - 4.1.2 Micro service-based architecture.
 - 4.1.3 Different redundancy model (i.e. Active-Active, Active-Standby, N-Way Active) for each type of microservices
 - 4.1.4 Capability to store and retrieve all security related information. Information shall range from security access levels to login times by user id, to password aging data.
 - 4.1.5 Modularity and have a distributed architecture.
 - 4.1.6 Implementation on carrier class server/cloud.
 - 4.1.7 Software executable (patch) upgrade with / without configuration migration.
- 4.2 Virtualised solution on generic COTS hardware or shall support Cloud Integration.
- 4.3 The NEs shall allow the independent scaling of the microservices.
- 4.4 The Dual Core system shall guarantee carrier-grade 99.999% system availability and avoid any Single Point of Failure.
- 4.5 The applications shall support different deployment options e.g. Metal server or container infrastructure.
- 4.6 No single failure of any module within the NE, shall lead to total disruption of service of that NE. Such failure shall also lead to minimum possible degradation of performance.
- 4.7 The NEs may have the capability of scale in/ scale out when certain KPI thresholds are reached such as CPU, Average Memory, and Load etc. Also, may support life cycle management procedures such as VNF/CNF instantiation & VNF/CNF termination manually and automatically.

- 4.8 The system shall be able to create, modify and delete commands from command classes. Also, system shall support definition of access privileges like read-only/write/import/export for groups or roles.
- 4.9 VNF/CNF shall maintain the feature parity with native solution.
- 4.10 VNF/CNF shall include application-level fault tolerance on compute, storage and network.
- 4.11 The NE may support Secure File Transfer Protocol like SFTP and SSH for login.
- 4.12 The NEs may have their own self-diagnostic functionality to provide their health information.
- 4.13 VNF/CNF shall provide and maintain Telecom Grade KPI.
- 4.14 VNF/CNF shall be agnostic to all 3GPP access types.
- 4.15 For security purpose, all components of Virtualized System, e.g. MANO, VNF/CNF depository etc. shall be hosted in India only.
- 4.16 VNF/CNF shall meet availability requirements as envisaged in this GR.
- 4.17 The system shall support mechanisms for system recovery and disaster recovery.
- 4.18 The system shall support scalability features to accommodate varying demands in disaster and temporary deployments efficiently.
- 4.19 The control software shall be responsible for logging and sending the log file on the network to a designated server (such as syslog or any other).
- 4.20 The NEs may be capable of providing the system configuration data to the Management Information Base (MIB) of the system (applicable with SNMP based management only).

CHAPTER 5

5 Other Requirements

5.1 Software Requirements

- 5.1.1 Modular, structured software written in High-Level Language
- 5.1.2 Software easy to handle during installation and normal operations as well as during extensions
- 5.1.3 Introduction of changes in software, wherever necessary, with least impact on other modules
- 5.1.4 Open-ended to allow addition of new features
- 5.1.5 Adequate flexibility to easily adopt changes in service features & facilities and technological evolution in hardware
- 5.1.6 Propagation of software faults is contained
- 5.1.7 Test programs to include fault tracing for detection and localization of system faults

5.2 Software Maintenance Requirements

- 5.2.1 Continuous supply of all software updates, for the period specified.
- 5.2.2 Integration of software updates without posing any problem to the existing functionality

5.3 Documentation

Detailed documentation in English shall be provided, including:

- 5.3.1 Self-explanatory user manual giving details of all functions, facilities and Procedures
- 5.3.2 Set-up and configuration parameters and procedures
- 5.3.3 Trouble shooting guide including fault dictionary.

Additionally, a soft copy of the documentation shall also be provided both in Hindi and English.

5.4 Quality Requirements

- 5.4.1. The manufacturer shall furnish the MTBF values. Minimum value of MTBF shall be specified by the purchaser. The calculations shall be based on the guidelines given in either BSNL QA document No. QM-115 {January 1997} "Reliability Methods and Predictions" or any other international standards.
- 5.4.2. The equipment shall be manufactured in accordance with international quality management system ISO 9001:2015 or any other equivalent ISO certificate for which the manufacturer should be duly accredited. A quality plan describing the quality assurance system followed by the manufacturer would be required to be submitted.
- 5.4.3. The equipment shall conform to the requirements for Environment specified in TEC QA standards QM-333 {Issue- March, 2010} (TEC 14016:2010) "Standard for Environmental testing of Telecommunication Equipment" or any other equivalent international standard, for operation, transportation and storage. The applicable environmental category A or B to be decided by the purchaser based on the use case. (This requirement is applicable only for hardware-based solutions.)

5.5 Safety Requirements

The equipment shall conform to relevant safety requirements as per IS/IEC 62368-1:2023 – "Audio/video, information and communication technology equipment - Part 1: Safety requirements" as prescribed under Table no. 1 of the TEC document 'SAFETY REQUIREMENTS OF TELECOMMUNICATION EQUIPMENT': TEC10009: 2024.

The manufacturer/supplier shall submit a certificate in respect of compliance to these requirements (These requirements are applicable for purposely built hardware or a physical entity only).

5.6 Security Requirements

The different 5G Dual Core components shall comply to the security requirements mentioned in the applicable Indian Telecommunication Security

	d) a voltage interruption corresponding to a reduction of supply voltage of >95% for 10ms.	d) Performance Criteria B for Voltage Interruption >95% duration :10ms (Note: In case of Battery back-up Performance Criteria A is applicable for above conditions.)
3	Immunity to voltage dips & short interruptions (applicable to only DC power input ports, if any): a) Voltage Interruption with 0% of supply for 10ms. b) Voltage Interruption with 0% of supply for 30ms, 100ms, 300ms and 1000ms. c) Voltage dip corresponding to 40% & 70% of supply for 10ms, 30 ms. d) Voltage dip corresponding to 40% & 70% of supply for 100ms, 300 ms and 1000 ms. e) Voltage variations corresponding to 80% and 120%of supply for 100 ms to 10s as per Table 1c of IEC 61000-4-29.	IEC 61000-4-29(2000) a) Applicable Performance Criteria shall be B. b) Applicable Performance Criteria shall be C. c) Applicable Performance Criteria shall be B. d) Applicable Performance Criteria shall be C. e) Applicable Performance Criteria shall be B.
4	Immunity to Electrostatic Discharge: Contact discharge level 2 { \pm 4 kV}	IEC-61000-4-2 Performance Criteria-B, Clause 9
5	Immunity to Electrostatic discharge: Air discharge level 3 { \pm 8 kV}	IEC-61000-4-2 Performance Criteria-B, Clause 9

6	<p>Immunity to Fast Transients (Burst): Test Level 2:</p> <p>a) 1 kV for AC/DC power port</p> <p>b) 0.5 kV for signal / control / data / telecom lines.</p>	<p>IEC 61000-4-4 (2012)</p> <p>Performance Criteria-B, Clause 9</p>
7	<p>Immunity to Radiated RF</p> <p>a) Radio Frequency: 80 MHz to 1 GHz, Electromagnetic field: 3V/m</p> <p>b) Radio Frequency: 800 MHz to 960 MHz, Electromagnetic field: 10V/m</p> <p>c) Radio Frequency: 1.4 GHz to 6 GHz, Electromagnetic field: 10V/m</p>	<p>IEC:61000-4-3 (2010);</p> <p>Performance Criteria-A, Clause 9</p>
8	<p>Immunity to conducted disturbance induced by Radio frequency fields:</p> <p>Under the test level 2 {3 V r.m.s.} in the frequency range 150 kHz-80 MHz for AC / DC lines and Signal /Control/telecom lines</p>	<p>IEC 61000-4-6 (2013)</p> <p>Performance Criteria-A, Clause 9</p>
9	<p>Immunity to Surges: AC/DC ports</p> <p>a) 2 kV peak open circuit voltage for line to ground</p> <p>b) 1kV peak open circuit voltage</p>	<p>IEC 61000-4-5 (2014)</p> <p>Performance Criteria-B, Clause 9</p>

	for line to line	
10	<p>Immunity to surges: Telecom ports</p> <p>a) 2kV peak open circuit voltage for line to ground coupling.</p> <p>b) 2 kV peak open circuit voltage for line-to-line coupling.</p>	<p>IEC 61000-4-5 (2014)</p> <p>Performance Criteria-C, Clause 9</p>

CHAPTER 6

6 Information for the Procurer of Product

Interfaces and features which are optional needs to be examined by the procurer and suitably specified in the tender conditions as per their requirement based on the deployment scenario specific to the procurer.

6.1 MME

S. No.	Parameter	Value
1.	Number of eNodeB Supported	
2.	Number of Attached Subscribers Supported	
3.	Number of Active Subscribers	
4.	Number of sessions	

6.2 P-GW-C + SMF / PGW-U+UPF/ S-GW

S. No.	Parameter	Value
1.	Number of IP Bearers	
2.	Packet Handling Capacity and Packet Size	
3.	Aggregate throughput	
4.	APN capacity	
5.	Number of Attached Subscribers	
6.	Number of Active Subscribers	
7.	Number of sessions	

8.	TPS	
----	-----	--

6.3 PCF+PCRF

S. No.	Parameter	Value
1.	Subscriber Capacity	
2.	Number of PDP sessions	
3.	TPS	

6.4 HSS+UDM

S. No.	Parameter	Option
1.	Number of Attached subscribers	
2.	TPS	

6.5 The procurer shall specify the minimum MTBF value for the solution, in accordance with Clause 5.4.1.

6.6 The applicable environmental category (A or B) for the solution shall be decided by the procurer, based on the intended use case, in accordance with Clause 5.4.3.

ABBREVIATIONS

3GPP	3rd Generation Partnership Project
5GC	5G Core
5G-EIR	5G-Equipment Identity Register
5GS	5G System
AF	Application Function
AMF	Access and Mobility Management Function
APN	Access Point Name
ARPF	Authentication credential Repository and Processing Function
AUSF	Authentication Server Function
CABs	Conformance Assessment Bodies
CHF	Charging Function
CLI	Command Line Interface
CMIP	Common Management Information Protocol
CN	Core Network
CNF	Cloud-Native Network Function
CORBA	Common Object Request Broker Architecture
COTS	Commercial Off-The-Shelf
CPU	Central Processing Unit

eNodeB	Evolved Node B
EMS	Element Management System
EPC	Evolved Packet Core
EPS	Evolved Packet System
ER	Essential Requirements
E-UTRAN	Evolved Universal Terrestrial Radio Access Network
GMLC	Gateway Mobile Location Centre
gNodeB	Next Generation Node B
GR	Generic Requirements
GUI	Graphical User Interface
HSS	Home Subscriber Server
HTTP	Hypertext Transfer Protocol
HTTPS	Hypertext Transfer Protocol Secure
IEC	International Electrotechnical Commission
IMSI	International Mobile Subscriber Identity
IRAT	Inter-Radio Access Technology
ISO	International Organization for Standardization
ITSAR	Indian Telecommunication Security Assurance Requirements
KPI	Key Performance Indicator

LI	Lawful Interception
LTE	Long-Term Evolution
MANO	Management and Orchestration
MBR	Maximum Bit Rate
MEC	Multi-access Edge Computing
MIB	Management Information Base
MM	Mobility Management
MME	Mobility Management Entity
MTBF	Mean Time between Failures
NAS	Non-Access-Stratum
NE	Network Element
NEF	Network Exposure Function
NF	Network Function
NG-RAN	Next Generation Radio Access Network
NMS	Network Management System
NRF	Network Repository Function
NSA	Non-Standalone
NSSAAF	Network Slice-Specific Authentication and Authorization Function
NSSF	Network Slice Selection Function

NWDAF	Network Data Analytics Function
OCS	Online Charging System
OFCS	Offline Charging System
OMC	Operation and Maintenance Center
PCF	Policy Control Function
PCRF	Policy and Charging Rules Function
PDN	Packet Data Network
PDU	Protocol Data Unit
PGW-C	Packet Data Network Gateway Control Plane Function
PGW-U	Packet Data Network Gateway User Plane Function
PLMN	Public Land Mobile Network
PM	Performance Management
QA	Quality Assurance
QoS	Quality of Service
RATs	Radio Access Technologies
REST	Representational State Transfer
RTECs	Regional Telecom Engineering Centers
S1AP	S1 Application Protocol
SA	Standalone

SAE	System Architecture Evolution
SBA	Service-Based Architecture
SBI	Service Based Interface
SFTP	Secure File Transfer Protocol
SGW	Serving Gateway
SGW-C	Serving Gateway Control Plane Function
SGW-U	Serving Gateway User Plane Function
SMF	Session Management Function
SNMP	Simple Network Management Protocol
SSH	Secure Shell
SUPI	Subscription Permanent Identifier
TCP/IP	Transmission Control Protocol/Internet Protocol
TPS	Transactions Per Second
UCMF	UE Radio Capability Management Function
UDM	Unified Data Management
UDR	Unified Data Repository
UDSF	Unstructured Data Storage Function
UE	User Equipment
UPF	User Plane Function

VNF Virtual Network Function

VoLTE Voice over Long-Term Evolution

VoNR Voice over New Radio

=====
===== End of the document =====